



Standard Consumer Safety Specification for Toy Safety¹

This standard is issued under the fixed designation F963; the number immediately following the designation indicates the year of original adoption or, in the case of revision, the year of last revision. A number in parentheses indicates the year of last reapproval. A superscript epsilon (ϵ) indicates an editorial change since the last revision or reapproval.

INTRODUCTION

The purpose of this consumer safety specification is to establish nationally recognized safety requirements for toys. Although this specification will not eliminate the need for the exercise of parental responsibility in selecting toys appropriate to the age of a child, or parental supervision in situations in which children of various ages may have access to the same toys, its application will minimize accidents in the normal, intended use and reasonably foreseeable abuse of the toys covered by this specification. This specification was developed originally as a Voluntary Product Standard under the auspices of the National Bureau of Standards, Department of Commerce, and published in 1976 (PS 72–76). The present revision is intended to update the safety requirements to include the following by reference: published federal mandatory requirements, relevant voluntary standards, certain new requirements for addressing potential hazards, and several technical revisions based on producer experience with the original standard.

1. Scope

1.1 This specification² relates to possible hazards that may not be recognized readily by the public and that may be encountered in the normal use for which a toy is intended or after reasonably foreseeable abuse. It does not purport to cover every conceivable hazard of a particular toy. This specification does not cover product performance or quality, except as related to safety. Except for the labeling requirements pointing out the functional hazards and age range for which the toy is intended, this specification has no requirements for those aspects of a toy that present an inherent and recognized hazard as part of the function of the toy. Such an example is a sharp point necessary for the function of a needle. The needle is an inherent hazard that is well understood by the purchaser of a toy sewing kit, and this hazard is communicated to the user as part of the normal educational process.

1.2 On the other hand, while a riding toy has inherent hazards associated with its use (for example, falling off onto the sidewalk), the possible hazards associated with its construction (sharp edges, exposed mechanisms, etc.) will be minimized by the application of this specification.

1.3 This specification covers requirements and contains test methods for toys intended for use by children under 14 years of age. Different age limits for various requirements will be found in this specification. These limits reflect the nature of the hazards and expected mental or physical ability, or both, of a child to cope with the hazards.

1.4 Articles not covered by this specification are as follows:

Bicycles

Tricycles

Non-Powered Scooters

(see Consumer Safety Specification [F2264](#))

Recreational Powered Scooters and Pocket Bikes

(see Consumer Safety Specification [F2641](#))

Sling shots and sharp-pointed darts

Playground equipment

Non-powder guns

Kites

Hobby and craft items in which the finished item is not primarily of play value

Model kits in which the finished item is not primarily of play value

Crayons, paints, chalks, and other similar art materials in which the material itself or the finished item is not primarily of play value, except that all art materials, whether or not a component of a toy, must comply with LHAMA, in accordance with [4.29.1-4.29.3](#).

Toy Chests

Sporting goods, camping goods, athletic equipment, musical instruments, juvenile products, and furniture; however, toys that are their counterparts are covered. (It is recognized that there is often a fine line between,

¹ This consumer safety specification is under the jurisdiction of ASTM Committee [F15](#) on Consumer Products and is the direct responsibility of Subcommittee [F15.22](#) on Toy Safety.

Current edition approved Dec. 1, 2011. Published December 2011. Originally approved in 1986. Last previous edition approved in 2008 as F963 – 08. DOI: 10.1520/F0963-11.

² Toy Industry Association, Inc. (TIA) sometimes provides its interpretations of this specification through its counsel as a service to its members and others. The TIA's interpretations are not reviewed or approved by ASTM and should be viewed as TIA's alone.

for example, a musical instrument or a sporting item and its toy counterpart. The intention of the producer or distributor, as well as normal use and reasonably foreseeable abuse, determines whether the item is a toy counterpart.)

Powered models of aircraft, rockets, boats, and land vehicles; however, toys that are their counterparts are covered.

Constant air inflatables

1.5 General guidelines for age labeling toys and toy packaging are contained in [Annex A1](#).

1.6 Information regarding packaging and shipping is contained in [Annex A2](#).

1.7 This consumer safety specification includes the following sections:

Title	Section
Scope	1
Referenced Documents	2
Terminology	3
Safety Requirements	4
Material Quality	4.1
Flammability	4.2
Toxicology	4.3
Electrical/Thermal Energy	4.4
Sound Producing Toys	4.5
Small Objects	4.6
Accessible Edges	4.7
Projections	4.8
Accessible Points	4.9
Wires or Rods	4.10
Nails and Fasteners	4.11
Plastic Film	4.12
Folding Mechanisms and Hinges	4.13
Cords and Elastics in Toys	4.14
Stability and Over-Load Requirements	4.15
Confined Spaces	4.16
Wheels, Tires, and Axles	4.17
Holes, Clearance, and Accessibility of Mechanisms	4.18
Simulated Protective Devices	4.19
Pacifiers	4.20
Projectile Toys	4.21
Teethers and Teething Toys	4.22
Rattles	4.23
Squeeze Toys	4.24
Battery-Operated Toys	4.25
Toys Intended to be Attached to a Crib or Playpen	4.26
Stuffed and Beanbag-Type Toys	4.27
Stroller and Carriage Toys	4.28
Art Materials	4.29
Toy Gun Marking	4.30
Balloons	4.31
Certain Toys with Nearly Spherical Ends	4.32
Marbles	4.33
Balls	4.34
Pompoms	4.35
Hemispheric-Shaped Objects	4.36
Yo Yo Elastic Tether Toys	4.37
Magnets	4.38
Jaw Entrapment in Handles and Steering Wheels	4.39
Safety Labeling Requirements	5
Instructional Literature	6
Producer's Markings	7
Test Methods	8
General	8.1
Testing for Hazardous Substance Content	8.2
Test Methods for Determination of Heavy Element Content in Toys, Toy Components and Materials	8.3
Tests for Cleanliness and Preservative Effectiveness	8.4
Normal Use Testing	8.5
Abuse Testing	8.6
Impact Tests	8.7

Torque Tests for Removal of Components	8.8
Tension Test for Removal of Components	8.9
Compression Test	8.10
Tests for Tire Removal and Snap-in Wheel and Axle Assembly Removal	8.11
Flexure Test	8.12
Test for Mouth-Actuated Toys	8.13
Projectiles	8.14
Test for Stability of Ride-On Toys	8.15
Stalled Motor Test for Battery-Operated Toys	8.17
Tests for Battery-Powered Ride-On Toys	8.18
Tests for Toys which Produce Noise	8.19
Dynamic Strength Test for Wheeled Ride-On Toys	8.20
Packaging Film Thickness	8.21
Test for Loops and Cords	8.22
Yo Yo Elastic Tether Toy Test Methods	8.23
Magnet Test Methods	8.24
Test Methods for Locking Mechanisms or Other Means	8.25
Identification	9
Age Grading Guidelines	Annex A1
Packaging and Shipping	Annex A2
Design Guidelines for Toys Attached to Cribs or Playpens	Annex A3
Design Guidelines for Bath Toy Projections	Annex A4
Flammability Testing Procedure for Solids and Soft Toys	Annex A5
Flammability Testing Procedure for Fabrics	Annex A6
Compositing Procedure for Total Heavy Metal Analysis	Annex A7
Rationale for 2007 Revisions	Annex A8
Rationale for 2008 Revisions	Annex A9
Rationale for 2011 Revisions	Annex A10

1.8 The values stated first are to be regarded as the standard. The values given in parentheses are for information only.

1.9 The following precautionary statement pertains only to the test methods portion, Section 8, of this specification: *This standard does not purport to address all of the safety concerns, if any, associated with its use. It is the responsibility of the user of this standard to establish appropriate safety and health practices and determine the applicability of regulatory limitations prior to use.*

2. Referenced Documents

2.1 ASTM Standards:³

- D374 Test Methods for Thickness of Solid Electrical Insulation
- D642 Test Method for Determining Compressive Resistance of Shipping Containers, Components, and Unit Loads
- D880 Test Method for Impact Testing for Shipping Containers and Systems
- D999 Test Methods for Vibration Testing of Shipping Containers
- D1193 Specification for Reagent Water
- D2240 Test Method for Rubber Property—Durometer Hardness
- D3421 Practice for Extraction and Determination of Plasticizer Mixtures from Vinyl Chloride Plastics⁴
- D4236 Practice for Labeling Art Materials for Chronic Health Hazards

³ For referenced ASTM standards, visit the ASTM website, www.astm.org, or contact ASTM Customer Service at service@astm.org. For *Annual Book of ASTM Standards* volume information, refer to the standard's Document Summary page on the ASTM website.

⁴ Withdrawn. The last approved version of this historical standard is referenced on www.astm.org.

- D5276** Test Method for Drop Test of Loaded Containers by Free Fall
- F404** Consumer Safety Specification for High Chairs
- F406** Consumer Safety Specification for Non-Full-Size Baby Cribs/Play Yards
- F834** Consumer Safety Specification for Toy Chests
- F1313** Specification for Volatile *N*-Nitrosamine Levels in Rubber Nipples on Pacifiers
- F1148** Consumer Safety Performance Specification for Home Playground Equipment
- F2264** Consumer Safety Specification for Non-Powered Scooters
- F2641** Consumer Safety Specification for Recreational Powered Scooters and Pocket Bikes
- F2853** Test Method for Determination of Lead in Paint Layers and Similar Coatings or in Substrates and Homogenous Materials by Energy Dispersive X-Ray Fluorescence Spectrometry Using Multiple Monochromatic Excitation Beams
- F2923** Specification for Consumer Product Safety for Children’s Jewelry
- 2.2 *ANSI Standards:*⁵
- C18.1** American National Standard for Dry Cells and Batteries—Specifications
- S1.4 Specification for Sound Level Meters
- Z315.1 Safety Requirements for Tricycles
- 2.3 *European Standards:*⁶
- EN 71-1** Safety of toys - Part 1: Mechanical and physical properties
- EN 71-3** Safety of toys - Part 3: Migration of certain elements
- 2.4 *Federal Standards:*⁷
- 15 CFR 1150 Marking of Toys, Look-Alike and Imitation Firearms
- 16 CFR 1303** Ban of Lead-Containing Paint and Certain Consumer Products Bearing Lead Containing Paint
- 16 CFR 1500 Hazardous Substances Act Regulations, including the following sections:
- 16 CFR 1500.3** (c) (6) (vi) Definition of “flammable solid”
- 16 CFR 1500.14** Products requiring special labeling under section 3(b) of the act
- 16 CFR 1500.18** Banned toys and other banned articles intended for use by children
- 16 CFR 1500.19** Misbranded toys and other articles intended for use by children
- 16 CFR 1500.44** Method for determining extremely flammable and flammable solids
- 16 CFR 1500.47 Method for determining the sound pressure level produced by toy caps
- 16 CFR 1500.48** Technical requirements for determining a

- sharp point in toys and other articles intended for use by children under 8 years of age
- 16 CFR 1500.49** Technical requirements for determining a sharp metal or glass edge in toys and other articles intended for use by children under 8 years of age
- 16 CFR 1500.50-53** Test method for simulating use and abuse of toys and other articles intended for use by children
- 16 CFR 1500.83** Exemptions for small packages, minor hazards, and special circumstances
- 16 CFR 1500.85** Exemptions from classification as banned hazardous substances
- 16 CFR 1500.86** Exemptions from classification as a banned toy or other banned article for use by children
- 16 CFR 1500.87** Children’s products containing lead: inaccessible component parts
- 16 CFR 1500.88** Exemptions from lead limits under section 101 of the Consumer Product Safety Improvement Act for certain electronic devices
- 16 CFR 1500.91** Determinations regarding lead content for certain materials or products under section 101 of the Consumer Product Safety Improvement Act
- 16 CFR 1501** Method for Identifying Toys and Other Articles Intended for Use by Children Under 3 Years of Age which Present Choking, Aspiration, or Ingestion Hazards Because of Small Parts
- 16 CFR 1505** Requirements for Electrically Operated Toys or Other Electrically Operated Articles Intended for Use by Children
- 16 CFR 1510** Requirements for Rattles
- 16 CFR 1511** Requirements for Pacifiers
- 16 CFR 1610** Standard for Flammability of Clothing Textiles
- 21 CFR 110** Current Good Manufacturing Practice in Manufacturing, Processing, Packaging, or Holding Human Food
- 21 CFR 170-189** Food for Human Consumption
- 21 CFR 700-740 Requirements for Specific Cosmetic Products
- 21 CFR 73, 74, 81, 82 Color Additives
- 49 CFR 173.100, 109 Definition of Class C Explosives
- CPSC-CH-E1001-08.1** Standard Operating Procedure for Determining Total Lead (Pb) in Metal Children’s Products (including Children’s Metal Jewelry)⁸
- CPSC-CH-E1002-08.1** Standard Operating Procedure for Determining Total Lead (Pb) in Non-Metal Children’s Products⁸
- CPSC-CH-E1003-09** Standard Operating Procedure for Determining Lead (Pb) in Paint and Other Similar Surface Coatings⁸
- CPSC-CH-E1004-11** Standard Operating Procedure for Determining Cadmium (Cd) Extractability from Children’s Metal Jewelry⁸

⁵ Electronic copy available from American National Standards Institute website: www.ansi.org; hard copies from Global Engineering Documents, 15 Inverness Way East, Englewood, CO 80112.

⁶ Available from European Committee for Standardization (CEN), Avenue Marnix 17, B-1000, Brussels, Belgium, <http://www.cen.eu>.

⁷ Available from U.S. Consumer Product Safety Commission website: www.cpsc.gov or U.S. Government Printing Office, Superintendent of Documents, P.O. Box 371954, Pittsburgh, PA 15250-7954; website: www.gpo.gov

⁸ Available from U.S. Consumer Product Safety Commission (CPSC), 4330 East West Hwy., Bethesda, MD 20814, <http://www.cpsc.gov>.

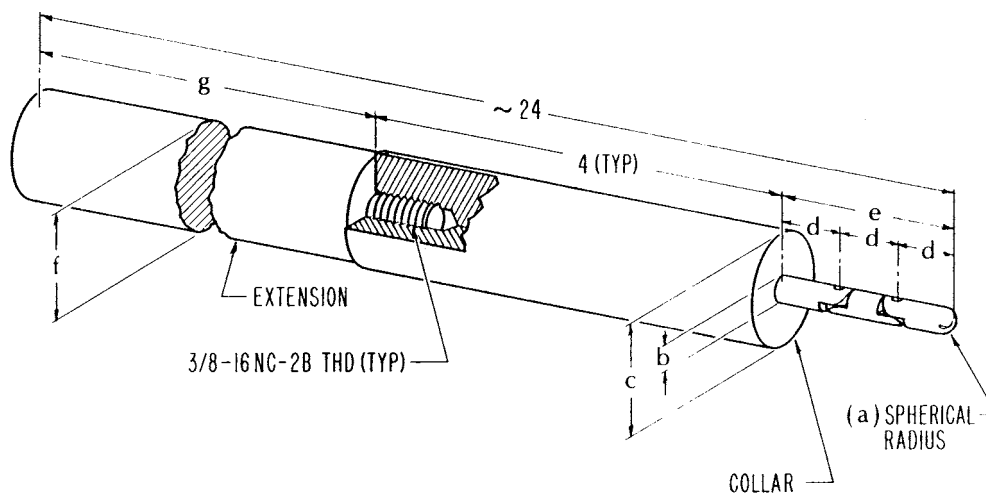

	a	b	c	d	e	f	g
(CHILDREN 0-36 MONTHS INCL)	PROBE A	.110	.220	1.020	.577	1.731	18 9/32
(" 37-96 ")	PROBE B	.170	.340	1.510	.760	2.280	17 25/32

ALL DIMENSIONS IN INCHES

FIG. 1 Accessibility Probes

SS-T-312B Tile, Floor: Asphalt, Rubber, Vinyl, VinylAsbestos⁹

Voluntary Product Standard PS 72-76 Toy Safety¹⁰

2.5 *ISO and IEC Standards:*¹¹

ISO 3696 Water for analytical laboratory use — Specification and test methods

ISO 3746:1995 Acoustics—Determination of Sound Power Levels of Noise Sources Using Sound Pressure—Survey Method Using an Enveloping Measurement Surface Over a Reflecting Plane

ISO 7779 Acoustics—Measurement of Airborne Noise Emitted by Computer and Business Equipment

ISO 8124-1 Safety of toys – Part 1: Safety aspects related to mechanical and physical properties

ISO 8124-3 Safety of toys – Part 3: Migration of certain elements

ISO 11202 Acoustics—Noise Emitted by Machinery and Equipment—Measurement of Emission Sound Pressure Levels at a Work Station and at Other Specified Positions—Survey Method in situ

ISO 11204 Acoustics—Noise Emitted by Machinery and Equipment—Measurement of Emission Sound Pressure Levels at a Work Station and at Other Specified Positions—Method Requiring Environmental Corrections

IEC 60086-2 Primary Batteries: Physical and Electrical Specifications

IEC 61672-1 Electroacoustics—Sound Level Meters—Part 1: Specifications

IEC 61672-2 Electroacoustics—Sound Level Meters—Part 2: Pattern Evaluation Tests

3. Terminology

3.1 *Definitions of Terms Specific to This Standard:*

3.1.1 *A-weighted sound pressure level (L_{pA})*—the sound pressure level obtained by using standardized A-weighting.

3.1.2 *accessible*—(part or component) describing any area of the toy that can be contacted by any portion forward of the collar of the accessibility probe as described in **16 CFR 1500.48** and **16 CFR 1500.49**. (See Fig. 1.)

NOTE 1—Dimensions are provided in Fig. 1 for two probes corresponding to two age ranges of children.

3.1.3 *alkaline battery*—a non-rechargeable dry cell battery with an alkaline manganese electrochemistry.

3.1.4 *aquatic toy*—an article, whether inflatable or not, intended to bear the mass of a child and used as an instrument of play in shallow water. This does not include bath toys, beach balls, and United States Coast Guard-approved life saving devices.

3.1.5 *art material*—any substance marketed or represented by the producer or repackager as suitable for use in any phase of the creation of any work of visual or graphic art of any medium. This definition includes items that become a component of the work of art such as paint, canvas, inks, crayons, chalk, solder, brazing rods, flux, paper, clay, stone, thread, cloth, and photographic film. It also includes items that are associated closely with the creation of the final work of art such as brushes, brush cleaners, solvents, ceramic kilns, silk screens, molds, mold making material, and photographic developing chemicals.

⁹ Available from U.S. Government Printing Office Superintendent of Documents, 732 N. Capitol St., NW, Mail Stop: SDE, Washington, DC 20401, <http://www.access.gpo.gov>.

¹⁰ Available from U.S. Government Printing Office Superintendent of Documents, 732 N. Capitol St., NW, Mail Stop: SDE, Washington, DC 20401, <http://www.access.gpo.gov>.

¹¹ Available from International Organization for Standardization (ISO), 1 rue de Varembe, Case postale 56, CH-1211, Geneva 20, Switzerland, <http://www.iso.ch>.

3.1.6 *ball*—any spherical, ovoid, or ellipsoidal object that is designed or intended to be thrown, hit, kicked, rolled, dropped, or bounced. The term “ball” includes any spherical, ovoid, or ellipsoidal object that is attached to a toy or article by means of string, elastic cord, or similar tether. The term “ball” also includes any multisided object formed by connecting planes into a generally spherical ovoid, or ellipsoidal shape that is designated or intended to be used as a ball. The term “ball” does not include dice, or balls permanently enclosed inside pinball machines, mazes, or similar outer containers. A ball is permanently enclosed if, when tested in accordance with 16 CFR 1500.53, it is not removed from the outer container.

3.1.7 *base material*—material upon which coatings may be formed or deposited.

3.1.8 *battery-operated toy*—toy having at least one function dependent on electricity and powered by batteries.

3.1.9 *burr*—a roughness that may be found at an edge or joint of a toy or component if the material is not severed or finished cleanly.

3.1.10 *button cell battery*—a battery having a diameter greater than its height.

3.1.11 *C-weighted peak sound pressure level (L_{Cpeak})*—the peak sound pressure level obtained when using standardized C-weighting.

3.1.12 *close-to-the-ear toy*—a toy that is intended to be used close to the ear, that is, the sound emitting part of such a toy is normally put against the ear of a child (example—toy telephones that emit sounds from the earpiece).

3.1.13 *coating*—all layers of material formed or deposited on the base material or toy and includes paints, varnishes, lacquers, or other substances of a similar nature, whether they contain metallic particles or not, which can be removed by scraping with a sharp blade as defined under 16 CFR 1303, et seq.

3.1.14 *collapse*—sudden or unexpected folding of a structure.

3.1.15 *compression spring*—spring which essentially returns to its initial state after compression.

3.1.16 *constant air inflatables*—structure relying on a continuous supply of air pressure supplied from one or more electrical blowers to maintain its shape, typically made of flexible fabric and designed for children’s use that may include but not be limited to the following activities: bounce, climb, slide, or interactive play.

3.1.17 *continuous sound*—any steady-state sound or group of variable sounds greater than one second in duration.

3.1.18 *cord*—a length of slender, flexible material including monofilaments, woven and twisted cord, rope, plastic textile tapes, ribbon, and those fibrous materials commonly called string.

3.1.19 *cosmetics*—any article intended or likely to be rubbed, sprinkled, or sprayed on, introduced onto, or otherwise applied to the human body for cleansing, beautifying, promoting or enhancing attractiveness, or for altering appearance.

3.1.20 *crushing*—injury to part of the body resulting from compression between two rigid surfaces.

3.1.21 *curled edge*—an edge in which the portion of the sheet adjacent to the edge is bent into an arc and forms an angle of less than 90° with the base sheet, as shown in Fig. 2.

3.1.22 *detection limit of a method*—three times the standard deviation of the blank value.

3.1.23 *discharge mechanism*—an inanimate system for releasing and propelling a projectile.

3.1.24 *driving mechanism*—assembly of linked parts or components (for example, gears, belts, winding mechanisms), at least one of which moves, powered by a source (for example, electrical or mechanical means) independent of the child.

3.1.25 *edge, hazardous*—an accessible edge that presents an unreasonable risk of injury during the normal use and reasonably foreseeable abuse of a toy. Metal and glass edges on toys intended for children under the age of eight years are defined as potentially hazardous if they fail the sharp edge test described in 16 CFR 1500.49. Edges other than metal and glass are defined as potentially hazardous if they are sharp to the touch under casual handling conditions.

3.1.26 *elastic*—material that will recover its former size and shape essentially and instantaneously after being elongated at least 10 % at a testing speed of not less than 20 in. (510 mm)/min.

3.1.27 *equivalent sound pressure level (L_{Aeq})*—the level of a steady-state sound which, in a stated time period and at a stated location, has the same A-weighted sound energy as the time-varying sound.

3.1.28 *explosive action*—the sudden release of energy characterized by the rapid expansion or bursting of a material.

3.1.29 *extension spring*—spring which essentially returns to its initial state after tension.

3.1.30 *fastener*—mechanical device which attaches two or more elements together (for example, screws, rivets, and staples).

3.1.31 *feathering*—the beveling of an edge (or decrease in thickness moving toward the edge) caused during the shearing or cutting of material.

3.1.32 *flash*—excess material that escapes between the mating parts of a mold assembly.

3.1.33 *folding mechanism*—an assembly of hinged, pivoted, folding, or sliding members that can produce a crushing, scissoring, pinching, or shearing action during operation.

3.1.34 *fuzz*—bits of fibrous-type material that can be readily removed from toys with a pile surface.

3.1.35 *hand-held toy*—a toy that is intended to be used or operated while being held in the hand. Examples include toy tools, small electronic games, stuffed animals, dolls, musical toys, and cap-firing toys.

3.1.36 *hazard*—any characteristic of a toy that presents an unreasonable risk of injury or illness during normal use or as a result of reasonably foreseeable abuse.

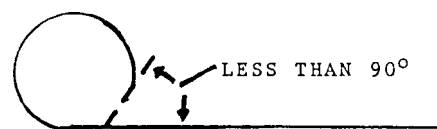

FIG. 2 Curled Edge

3.1.37 *hazardous magnet*—a magnet which has a flux index >50 (refer to test method in 8.24.1) and which is a small object (refer to 4.6 and Fig. 3).

3.1.38 *hazardous magnet component*—any part of a toy that is a small object (refer to 4.6 and Fig. 3) and which contains an attached or imbedded magnet which has a flux index >50 as determined in accordance with the test method in 8.24.1.

3.1.39 *helical spring*—spring in the form of a coil.

3.1.40 *hemmed edge*—an edge in which the portion of the sheet adjacent to the edge is folded back on the sheet itself through an angle of approximately 180°, so that the portion of the sheet adjacent to the edge is approximately parallel to the main sheet, as shown in Fig. 4.

3.1.41 *hinge-line clearance*—the distance between the stationary portion of a toy and the movable portion along, or adjacent to, a line projected through the axis of rotation, shown as Dimension A in Fig. 5.

3.1.42 *impulsive sound*—any sound that is characterized by a brief excursion of sound pressure significantly exceeding the ambient noise, typically less than one second in duration.

3.1.43 *juvenile products*—consumer products designed or intended primarily for use by children which are not used primarily for play. These include, but are not limited to, items such as bassinets/cradles, bath seats, infant bath tubs, carriages and strollers, changing tables, full size cribs, gates and enclosures, handheld infant carriers, high chairs, infant bouncers, infant swings, play yards/non-full size cribs, portable bed rails, portable hook-on chairs, soft infant carriers, stationary activity centers, toddler beds and walkers.

3.1.44 *lap joint*—a joint in which an edge overlaps a parallel surface but is not necessarily attached to it mechanically at all points along the length, as in the examples shown in Fig. 6.



FIG. 4 Hemmed Edge

3.1.45 *large and bulky toy*—toy that has a projected base area of more than 400 in.² (0.26 m²) or a volume of more than 3 ft³ (0.08 m³) calculated without regard to minor appendages.

NOTE 2—The base area for toys having permanently attached legs is measured by calculating the area enclosed by straight lines connecting the outermost edge of each leg of the perimeter.

3.1.46 *latex balloon*—any toy or decorative item consisting of a latex bag that is designed to be inflated by air or gas. The term does not include inflatable children’s toys that are used in aquatic activities such as rafts, water wings, swim rings, or other similar items.

3.1.47 *marble*—a sphere made of a hard material, such as glass, agate, marble, or plastic, that is used in various children’s games, generally as a playing piece or marker. The term “marble” does not include a marble permanently enclosed in a toy or game. A marble is permanently enclosed if, when tested in accordance with 16 CFR 1500.53, it is not removed from the toy or game.

3.1.48 *materials intended to leave a trace*—graphite material in pencils, liquid in pens, and similar substances.

3.1.49 *maximum A-weighted sound pressure level (L_{AFmax})*—the maximum sound pressure level obtained when using standardized A-weighting and fast detector response (time-weighting).

3.1.50 *non-replaceable battery*—an electrochemical device that will not require user accessibility or user replacement for the expected life of the product or devices it is intended to power. Such batteries will not be accessible when tested in accordance with the normal use and, where appropriate, reasonably foreseeable abuse tests of 8.6 through 8.10.

3.1.51 *normal use*—play modes that conform to the instructions accompanying the toy, that have been established by tradition or custom, or that are evident from an examination of the toy.

3.1.52 *other materials, whether mass colored or not*—materials such as wood, leather, and other porous substances which may absorb coloring matter without forming a coating.

3.1.53 *packaging*—material accompanying the toy when purchased, but having no intended play function.

3.1.54 *peak sound pressure level (L_{Cpk})*—the greatest C-weighted instantaneous sound pressure level within the period of observation.

3.1.55 *pinching*—created when two moving or one moving and one fixed surface come together in such a way that they could entrap and compress flesh, usually resulting in a contusion or laceration.

3.1.56 *point, hazardous*—an accessible point that presents an unreasonable risk of injury during normal use or reasonably foreseeable abuse. Points on toys intended for children under the age of 8 years are potentially hazardous if they fail the sharp point test described in 16 CFR 1500.48.

3.1.57 *pompom*—lengths or strands of fiber, yarns, or threads clamped or secured and tied in the center, and brushed

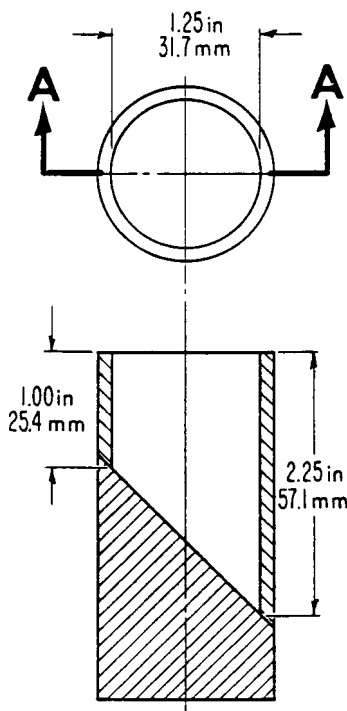
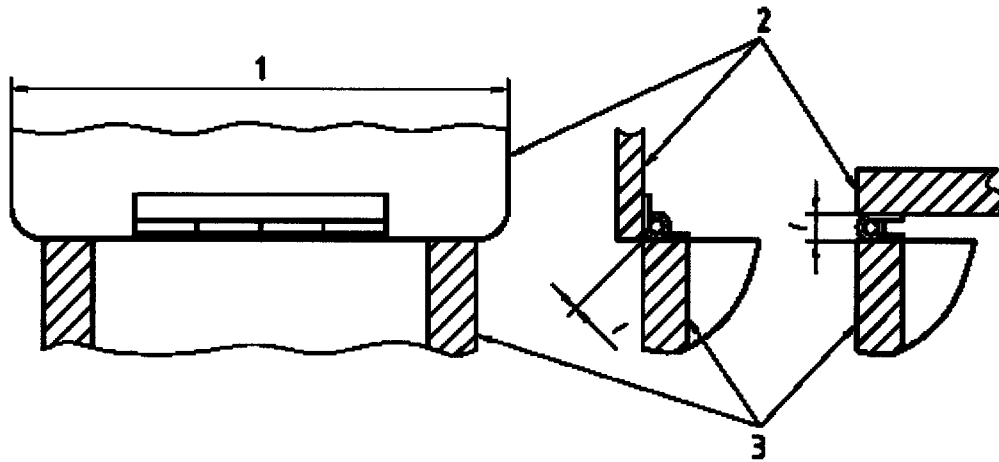

FIG. 3 Small Parts Cylinder



Key

- 1 Hinge line
- 2 Lid
- 3 Box

l = Hinge-line clearance

FIG. 5 Changing Clearance at Hinge Line

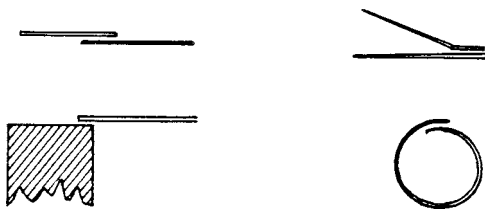

FIG. 6 Typical Lap Joints

up to form a spherical shape. Also included are spherical-shaped attachments made of stuffed material.

3.1.58 *principal display panel*—the display panel for a retail package or container, bin, or vending machine that is most likely to be displayed, shown, presented, or examined under normal or customary conditions of display for retail sale.

3.1.59 *projectile*—an object propelled by means of a discharge mechanism capable of storing and releasing energy under the control of the operator.

3.1.60 *projection, hazardous*—a projection that, because of its material or configuration, or both, may present a puncture hazard if a child should fall onto it. Excluded from this definition are puncture hazards to the eyes or mouth, or both, because of the impossibility of eliminating puncture hazards to those areas of the body by product design.

3.1.61 *protective cap or cover*—a component that is attached to a potentially hazardous edge or projection to reduce the possibility of injury.

3.1.62 *protective tip*—a component that is attached to the impacting end of a projectile to minimize injury if it should impact on the body, and also to prevent damage to the projectile upon striking a target, provide a means of attaching the projectile to the target as in the case of suction cups, or prevent damage to inanimate objects.

3.1.63 *rattle*—a toy that is clearly designed to emit sound when shaken typically intended for children under 18 months.

3.1.64 *reasonably foreseeable abuse*—conditions to which a child may subject a toy that are not normal use conditions, such

as deliberate disassembly, dropping, or using the toy for a purpose for which it was not intended. Simulated use and abuse tests for toys are given in [16 CFR 1500.50-53](#) (excluding the bite test, Paragraph (c), of each section).

3.1.65 *reference box*—a hypothetical surface which is the smallest rectangular parallelepiped that encloses the toy without regard to minor appendages.

3.1.66 *rigid*—any material having a hardness exceeding 70 Shore A scale durometer, as measured by the latest revision of Test Method [D2240](#).

3.1.67 *rolled edge*—an edge in which the portion of the sheet adjacent to the edge is bent into an arc and forms an angle between 90 and 120° with the main sheet, as shown in [Fig. 7](#).

3.1.68 *scraping*—mechanical removal of coatings down to the base material without damaging the substrate material.

3.1.69 *simulated protective equipment*—toys designed to mimic products that infer some sort of physical protection to the wearer (for example, protective helmets and visors).

3.1.70 *soft-filled toy/stuffed toy*—toy, clothed or unclothed, with soft body surfaces and filled with soft materials, allowing compression of the torso readily with the hand.

3.1.71 *splinter*—sharp pointed fragment.

3.1.72 *spiral spring*—clockwork-type spring.

3.1.73 *squeeze toy*—a handheld pliable toy, intended for children under the age of 18 months, usually incorporating a noise-making feature activated by forcing air through an opening when flexed or squeezed, and which recovers to its original shape when released.

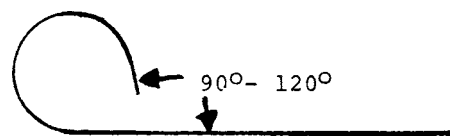

FIG. 7 Rolled Edge

3.1.74 *steady-state sound (noise)*—noise in which there are negligibly small fluctuations of sound pressure level within the period of observation.

3.1.75 *strap*—a piece of flexible material in which the width is significantly greater than the thickness.

3.1.76 *substrate material*—all of the accessible materials present in toys, other than paint or similar surface coatings.

3.1.77 *tabletop, floor, and crib toy*—toys intended to be played with while attached to or resting on a table top, floor, or crib. Examples of such toys include, but are not limited to, toy vehicles, stacking toys, large and bulky toys, games, and activity toys that attach to crib rails.

3.1.78 *tangle or form a loop*—loops that are formed by reasonably foreseeable manipulation of the cord/strap/elastic. Loops that are formed by excessive or intricate manipulations, or both, of the cord/strap/elastic shall be considered as exempt.

3.1.79 *teether*—toy designed for oral use and intended primarily for symptomatic relief of teething discomfort.

3.1.80 *tool*—screwdriver, coin, or other object which may be used to operate a screw, clip, or similar fixing device.

3.1.81 *toy*—any object designed, manufactured, or marketed as a plaything for children under 14 years of age.

3.1.82 *toy chest*—toy boxes that are designed and marketed as storage containers for toys. The products subject to the requirements are those with a volume of 1.1 ft³ (0.031 m³) or more.

3.1.83 *toy seat*—a stationary toy product with a seat where the amusement of the child is a primary function of the product and the play pattern intends that the child be in a seated position.

3.1.83.1 *Discussion*—Play features may include, but are not limited to, sliding or rotating features, learning toys, manually actuated music etc. with which the seated child may interact. Children’s furniture products without any interactive play features such as stools, chairs, patio sets, rocking chairs, picnic tables, storage units etc. are not considered toy seats. In addition, juvenile products such as bouncers, infant seats, stationary activity centers etc. are not considered toy seats.

3.1.84 *yo yo elastic tether toy*—a toy consisting of an elastic tether that usually contains a loop on one end to wear around the finger, and a flexible object on the other end intended to be thrown and returned to the hand.

4. Safety Requirements

4.1 *Material Quality*—Toys may be made from new or reprocessed materials and shall be visually clean and free from infestation. The materials shall be assessed visually by the unaided eye rather than under magnification. If reprocessed materials are used, they must be refined so that the level of hazardous substances conforms to the requirements of 4.3.1.

4.2 *Flammability*—Materials other than textiles (excluding paper) used in toys shall not be flammable, as defined under 16 CFR 1500.3 (c) (6) (vi) under the Federal Hazardous Substances Act (FHSA) (see 16 CFR 1500). For testing purposes, any textile fabrics used in toys shall comply with 16 CFR 1610. A test procedure for testing flammability of toys, which is an interpretation of 16 CFR 1500.44, is contained in Annex A5. A procedure for testing the flammability of fabrics is contained in Annex A6.

4.3 *Toxicology:*

4.3.1 *Hazardous Substances*—Toys or materials used in toys shall conform to the FHSA and to the regulations promulgated under that act. Exemptions to this act for certain types of toys are given in 16 CFR 1500.85. The regulations define limits for substances that are toxic, corrosive, an irritant, sensitizer or pressure generating, and radioactive, flammable, and combustible materials. Testing references for hazardous substance content are given in 8.2. It should be noted that specific states may have hazardous substances regulations that are more restrictive than the Federal regulations.

4.3.2 *Manufacturing and Packaging of Food*—All food products supplied with toys shall be manufactured and packaged in compliance with 21 CFR 110, which is concerned with the sanitation practices for the manufacture, processing, packaging, or holding of human food.

4.3.3 *Indirect Food Additives*—Toy components intended to be used in contact with food, such as toy cooking utensils, shall conform to the applicable requirements of the Food, Drug and Cosmetic Act (FDCA), specifically 21 CFR 170 through 189.

4.3.3.1 *Toys in Contact with Food*—Toys comprising components intended to be used in contact with food, such as toy cooking utensils and toy tableware shall meet the requirements of 6.7 for instructional literature.

4.3.3.2 *Ceramicware, Lead, and Cadmium Contamination*—Ceramic toy components intended or likely to hold food, such as a porcelain tea set, shall conform to the applicable requirements of the FDCA, Section 402 (a) (2) (c), and FDA Compliance Policy Guides.

4.3.4 *Cosmetics*—Cosmetics shall conform to the requirements of the Federal FDCA as codified in 21 CFR. The regulations applicable to cosmetics are stated in 21 CFR 700 through 740. The color additive regulations applicable to cosmetics are found in 21 CFR 73, 74, 81, and 82.

4.3.4.1 In addition, cosmetics intended for use by children under 8 years of age shall meet all requirements of this specification and the FHSA regulations, notwithstanding the exclusions of 16 CFR 1500.81 and 1500.3 (b) (4) (ii).

4.3.4.2 The requirements from the Food and Drug Administration (FDA) will therefore be additive to those existing for children’s products.

4.3.5 *Heavy Elements:*

4.3.5.1 *Paint and Similar Surface-Coating Materials*—Paint and other similar surface-coating materials applied to toys shall comply with the lead content provisions of 16 CFR 1303, issued under the Consumer Product Safety Act (CPSA), as amended by the Consumer Product Safety Improvement Act of 2008 (CPSIA).

(1) This regulation prohibits the use of paints or similar surface-coating materials that contain lead or lead compounds and in which the lead content (calculated as lead metal [Pb]) is in excess of 0.009 % (90 ppm) of the weight of the total nonvolatile content of the paint or the weight of the dried paint film.

(2) In addition, surface-coating materials shall not contain compounds of antimony, arsenic, barium, cadmium, chromium, lead, mercury, or selenium, of which the metal content of the soluble material is in excess of the levels by weight of

the contained solids (including pigments, film solids, and driers) given in **Table 1**. The analytical results obtained should be adjusted in accordance with the test method in 8.3.4.3 prior to comparing them to the values in **Table 1**. To determine conformance, the soluble level shall be determined by dissolving the contained solids (dried film including pigments, film solids, and driers) as specified in 8.3.2.

4.3.5.2 *Toy Substrate Materials*—These requirements are designed to reduce children’s exposure to heavy elements contained in accessible toy substrate materials. (For requirements for surface coating materials, see 4.3.5.1.)

(1) *Scope*—This section specifies requirements and test methods for total lead and the migration of antimony, arsenic, lead, barium, cadmium, chromium, mercury and selenium in accessible substrate materials. Accessible glass, metal and ceramic toys or parts of toys, that are small parts (that is, that fit into the test fixture specified at 16 CFR 1501 (see Fig. 3), are also subject to this requirement.

(a) Accessibility of parts shall be determined as defined in 3.1.2 before and after use and abuse testing described in 8.4-8.9.

(b) Toys and parts of toys which, due to their inaccessibility, size, mass, function, or other characteristics, cannot be sucked, mouthed or ingested are not subject to this requirement.

NOTE 3—For the purposes of this requirement, the following criteria are considered reasonably appropriate for the classification of toys or parts likely to be sucked, mouthed or ingested: (1) All toy parts intended to be mouthed or contact food or drink, components of toys which are cosmetics, and components of writing instruments categorized as toys; (2) Toys intended for children less than 6 years of age, that is, all accessible parts and components where there is a probability that those parts and components may come into contact with the mouth.

(c) Packaging materials are not subject to these requirements unless they are intended to be retained as part of the toy or are intended to provide play value.

(d) This requirement is not intended to apply to children’s jewelry, which is addressed by Specification F2923.

(e) In addition, materials now or in future listed in the most current revision of 16 CFR 1500.88 or 16 CFR 1500.91 as exempt from testing and certification requirements are excluded from this requirement for the purposes of determining compliance.

(2) *Requirements:*

(a) Accessible component parts of children’s products (as defined in 3.1.2 and in 16 CFR 1500.87, before and after use and abuse testing described in 8.4-8.9 and in 16 CFR 1500.50-53 and 16 CFR 1500.87) must not contain lead or lead compounds in which the lead content (calculated as lead metal [Pb]) is in excess of 100 ppm (300 ppm for products manufactured or imported prior to August 14, 2011) of the weight of the component, except as provided under 16 CFR 1500.88 and 16 CFR 1500.91.

TABLE 1 Maximum Soluble Migrated Element in ppm (mg/kg) for Surface Coatings and Substrates Other Than Modeling Clay Included as Part of a Toy

Antimony (Sb)	Arsenic (As)	Barium (Ba)	Cadmium (Cd)	Chromium (Cr)	Lead (Pb)	Mercury (Hg)	Selenium (Se)
60	25	1000	75	60	90	60	500

(b) The migration of elements from toys and parts of toys as specified in 4.3.5.2(1) shall not exceed the limits specified in **Table 1** when tested in accordance with the methods set forth in 8.3. Modeling clays included as part of a toy shall not exceed the limits specified in **Table 2** when tested in accordance with the methods set forth in 8.3. Please note that the limits in **Table 2** apply only to these materials as a component of a toy; in addition, please also note that if the primary purpose of the material is to create a tangible work of art, it may in addition be subject to the requirements of 16 CFR 1500.14.

(c) In addition, metallic toys or metallic toy components which are small parts may not exhibit extraction of more than 200 µg of cadmium when tested per 8.3.5.5(3). Compliance with all of the above requirements may be established by a screen of total element content as specified in 8.3.1.

4.3.6 *Cosmetics, Liquids, Pastes, Putties, Gels, and Powders*—The purpose of this requirement is to minimize the risk associated with the lack of cleanliness, shelf life, and contamination of cosmetics, liquids, pastes, putties, gels, and powders used in toys (excluding art materials). It sets standards for cleanliness and the ability to withstand extended shelf life or contamination, or both, during use without microbiological degradation.

4.3.6.1 Water used in the manufacturing and filling of toys shall be prepared according to the bacteriological standards for USP Purified Water. (**Warning**—The various methods for producing purified water each present different potentials for contaminating the final product. Purified water produced by distillation is sterile, provided that the production equipment is suitable and sterile. On the other hand, ion-exchange columns and reverse osmosis units require special attention in that they afford sites for microorganisms to foul the system and contaminate the effluent. Frequent monitoring may thus be called for, particularly with the use of these units following periods of shutdown of more than a few hours.)

4.3.6.2 The formulations of these products used in toys shall be such that they are not subject to microbial degradation during shelf life or reasonably foreseeable use.

4.3.6.3 The cleanliness of these products used in toys and their ingredients shall be determined in accordance with 8.4.1. Formulations used to prevent microbial degradation shall be evaluated in accordance with 8.4.2.

4.3.6.4 Formulations of cosmetics shall be evaluated for potential microbiological degradation in accordance with 8.4.2.

4.3.7 *Stuffing Materials*—Loose fillers for stuffed toys shall be free of objectionable matter originating from insect, bird, rodent, or other animal infestation and of contaminants, such as splinters and metal chips to the extent possible in good manufacturing practice. The test methods that shall be used to determine objectionable material are in Chapter 16 of *Official Methods of Analysis of the Association of Official Analytical*

TABLE 2 Maximum Soluble Migrated Element in ppm (mg/kg) for Modeling Clays Included as Part of a Toy

Antimony (Sb)	Arsenic (As)	Barium (Ba)	Cadmium (Cd)	Chromium (Cr)	Lead (Pb)	Mercury (Hg)	Selenium (Se)
60	25	250	50	25	90	25	500

Chemists.¹² In addition, fiber filling, whether natural or synthetic, should meet the requirements of Title 34, Chapter 47, Section 47.317, “Tolerances of the Commonwealth of Pennsylvania Regulation for Stuffed Toys.”

4.3.8 *DEHP (DOP)*—Pacifiers, rattles, and teethingers shall not intentionally contain DI (2-ethylhexyl) phthalate (also known as dioctyl phthalate). To prevent trace amounts of DEHP (DOP) from affecting analysis, up to 3 % of total solid content will be accepted in the result, when tested in accordance with Practice **D3421**.

4.4 *Electrical/Thermal Energy*—Toys operating from nominal 120-V branch circuits shall conform to **16 CFR 1505**, issued under the FHSA.

4.5 *Sound-Producing Toys*—These requirements are intended to minimize the possibility of hearing damage that might be caused by toys that are designed to produce sound. These requirements are applicable before and after testing in accordance with **8.5** through **8.10**. These requirements do not apply to: (1) sounds produced by mouth-actuated toys where the sound pressure level is determined by the blowing action of the child; (2) child-actuated sounds such as those produced by xylophones, bells, drums, and squeeze toys where the sound pressure level is determined by the muscular action of the child. The continuous sound pressure requirements do not apply to rattles; however, rattles are covered by impulsive sound pressure requirements; (3) radios, tape players, CD players, and other similar electronic toys and toys where the sound output is dependent on the content of removable media (for example, game cartridge, flash cards, and so forth); (4) toys that are connected to or interfaced with external devices (for example, televisions, computers) where the sound pressure level is determined by the external device; and (5) sound emitted from earphones/headphones.

4.5.1 *Requirements*—When tested in accordance with **8.19**, toys that are designed to emit sound shall conform to the following requirements:

4.5.1.1 The A-weighted equivalent sound pressure level, L_{Aeq} , of continuous sounds produced by close to the ear toys shall not exceed 65 dB.

4.5.1.2 The A-weighted equivalent sound pressure level, L_{Aeq} , of continuous sounds produced by all other toys except close-to-the-ear toys and push/pull toys shall not exceed 85 dB.

4.5.1.3 The C-weighted peak sound pressure level, L_{Cpeak} , of impulsive sounds produced by close to the ear toys shall not exceed 95 dB.

4.5.1.4 The C-weighted peak sound pressure level, L_{Cpeak} , of impulsive sounds produced by any type of toy excluding toys using explosive action (for example, percussion caps) shall not exceed 115 dB.

4.5.1.5 The C-weighted peak sound pressure level, L_{Cpeak} , of impulsive sounds produced by a toy using percussion caps or other explosive action shall not exceed 125 dB.

4.6 *Small Objects*—These requirements are intended to minimize the hazards from choking, ingestion, or inhalation to children under 36 months of age created by small objects.

4.6.1 Toys that are intended for children under 36 months of age are subject to the requirements of **16 CFR 1501**. Criteria for determining which toys are subject to these requirements are provided, in part, in 16 CFR 1500.50 and 1501 and also in **Annex A1** of this specification. The requirements of **16 CFR 1501** state, in part, that no toy (including removable, liberated components, or fragments of toys) shall be small enough without being compressed to fit entirely within a cylinder of the specified dimensions as shown in **Fig. 3**. For the purposes of this specification, fragments of toys include, but are not limited to, pieces of flash, slivers of plastics, pieces of foam, or fine bits or shavings. Pieces of paper, fabric, yarn, fuzz, elastic, and string are excluded from this requirement.

4.6.1.1 The requirements are applicable before and after use and abuse testing in accordance with Section **8** to determine the accessibility of small objects such as small toys or components of toys including eyes, squeakers, or knobs, or pieces that break off or are removed from toys.

4.6.1.2 The following articles are exempt from the requirements: balloons; books and other paper articles; writing materials (crayons, chalk, pencils, and pens); phonograph records and compact discs (CDs); modeling clay and similar products; and fingerpaints, watercolors, and other paint sets. A listing of exempt articles is provided in 16 CFR 1501.3.

4.6.1.3 Toys that are intended to be assembled by an adult and contain potentially hazardous small objects in the unassembled state shall be labeled in accordance with **5.8**.

4.6.2 *Mouth-Actuated Toys*—This requirement relates to toys, such as noisemakers, that are intended to be actuated repeatedly by blowing or sucking. Mouth-actuated toys that contain loose objects, such as spheres in a whistle, or inserts, such as reeds in a noisemaker, shall not release an object that will fit within the small parts test cylinder, as shown in **Fig. 3**, when air is alternately blown and sucked rapidly through the mouthpiece, according to the procedure described in **8.13**. The procedure of **8.13** shall also be applied to the outlet if the air outlet is capable of being inserted into or covered by the mouth.

4.6.2.1 Small objects contained in an inflatable toy shall not be liberated during inflation or deflation.

4.6.3 Toys and games that are intended for use by children who are at least three years old (36 months) but less than six years of age (72 months) are subject to the requirements of **16 CFR 1500.19**. With the exception of products such as paper punch-out games and similar items, any toy or game that is intended for use by children who are at least three years old (36 months) but less than six years of age (72 months) and includes a small part is subject to the labeling requirements in accordance with **5.11.2**.

4.7 *Accessible Edges*—Toys shall not have accessible, potentially hazardous sharp edges. Toys that are intended to be assembled by an adult, and may contain unprotected potentially hazardous sharp edges in the unassembled state, shall be labeled in accordance with **5.8**.

4.7.1 Potentially hazardous sharp metal and glass edges are defined in **16 CFR 1500.49**. Toys intended for use by children under 8 years of age are subject to this requirement before or

¹² “Extraneous Materials: Isolation,” *Official Methods of Analysis of the Association of Official Analytical Chemists*, 15 ed., Chapter 16, 1990.

after use and abuse testing, or both, as specified in 8.5-8.10. An illustration of a sharp edge tester is shown in Fig. 8.

4.7.2 Toys containing potentially hazardous edges that are a necessary part of the function of a toy shall carry cautionary labeling as specified in 5.10 if the toy is intended for use by children from 48 to 96 months. Toys intended for children aged less than 48 months shall not have accessible hazardous functional sharp edges.

4.7.3 *Metal Toys*—Accessible metal edges, including holes and slots, shall be free of hazardous burrs and feathering, or shall be hemmed, rolled, or curled, or shall be covered with a permanently affixed device or finish.

NOTE 4—Regardless of the manner in which edges are finished, they are subject to the sharp edge technical requirements as described in 4.7.1. If a device is used to protect an edge, it shall not become detached after being tested in accordance with the appropriate procedures described in 8.5-8.10.

4.7.4 *Molded Toys*—Accessible edges, corners, or mold parting areas of molded toys should be free of hazardous edges produced by burrs and flash or so protected that hazardous edges are not exposed.

4.7.5 *Exposed Bolts or Threaded Rods*—If the ends of bolts or threaded rods are accessible, the thread shall be free of exposed, hazardous sharp edges and burrs, or the ends shall be covered by smooth finish caps so that hazardous sharp edges and burrs will not be exposed. Any caps that are used shall be subjected to the compression test noted in 8.10, regardless of whether the cap is accessible to flat-surface contact during the appropriate impact test(s) described in 8.7. Protective caps shall also be subjected to the tension test in 8.9 and the torque test in 8.8.

4.8 *Projections*—This requirement relates to potentially hazardous projections in all toys intended for use by children under 8 years of age. This requirement is intended to minimize possible puncture hazards to the skin that might be caused if a child were to fall on a rigid projection, such as unprotected ends of axles, actuating levers, and decorative features. Due to the extremely sensitive nature of the eyes and interior of the mouth, this requirement will not, nor is it intended to, provide protection to those areas of the body. If a projection appears to

present a potential skin puncture hazard, the projection shall be protected by suitable means, such as by turning back the end of a wire or by affixing a smoothly finished protective cap or cover, which effectively increases the surface area for potential contact with the skin. Toys shall meet this requirement both before and after testing in accordance with 8.5-8.10. Toys intended to be repeatedly assembled and taken apart shall have the individual pieces and fully assembled articles, as shown on packaging graphics, instructions or other advertising, evaluated separately. The requirements for the assembled toy do not apply to toys where the assembling makes up a significant part of the play value of the toy. Since this requirement relates to hazards arising from a child falling onto a toy, only vertical or nearly vertical projections are required to be evaluated. The toy shall be tested in its most onerous position. Corners of structures are excluded from this requirement.

4.8.1 *Bath Toy Projections*—Rigid projections on toys designed primarily for use in the bath tub may pose a specific hazard that can result in serious penetration and impalement injuries. Additional design guidelines specifically for bath toy projections are provided in Annex A4 of this specification. As there are no objective means for determining conformance with these guidelines, they are not to be used to judge compliance with this specification.

4.9 *Accessible Points*—Toys shall not have accessible, potentially hazardous sharp points that may occur because of the following: configuration of the toy; assembly devices such as wires, pins, nails, and staples that are fastened poorly; poorly sheared sheet metal; burrs on screws; and splintered wood. Toys that are intended to be assembled by an adult and may contain potentially hazardous sharp points in the unassembled state shall be labeled in accordance with 5.8.

4.9.1 Potentially hazardous sharp points are defined by 16 CFR 1500.48. Toys intended for use by children under 8 years of age are subject to this requirement before or after use and abuse testing, or both, as specified in 8.5-8.10. An illustration of a sharp-point tester is shown in Fig. 9.

4.9.2 Toys in which an accessible, potentially hazardous sharp point is a necessary function of the toy, such as a needle in a sewing kit, shall carry cautionary labeling as specified in

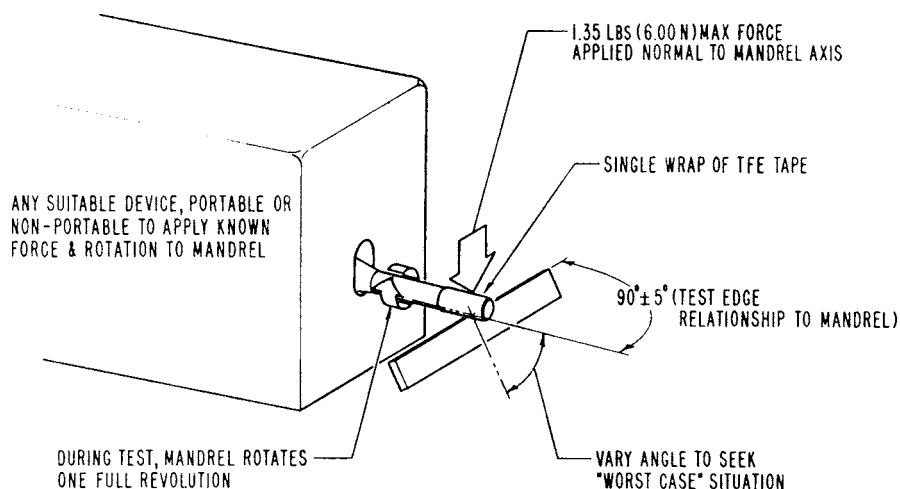

FIG. 8 Principle of Sharp Edge Test

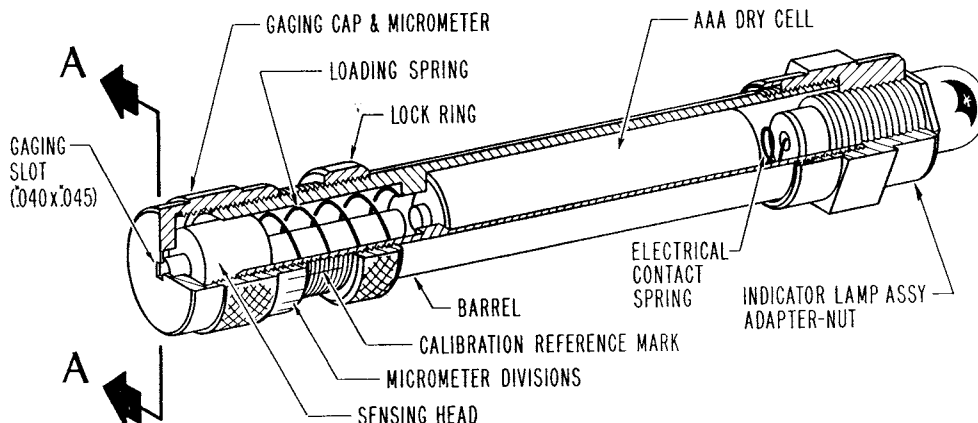
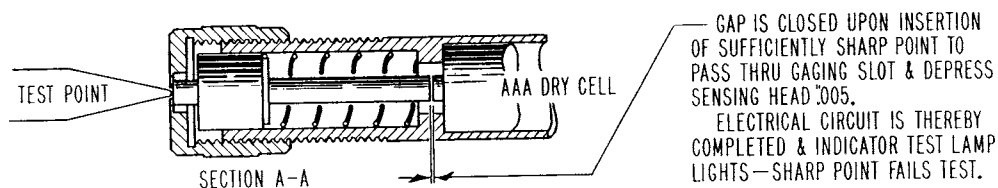

FIG. 9 Sharp Point Tester

5.10, if the toy is intended for children from 48 to 96 months old. Toys intended for children less than 48 months old shall not have accessible hazardous functional points.

4.9.3 *Wood*—The accessible surfaces and edges of wood used in toys shall be free of splinters, both before and after being tested in accordance with the appropriate procedures described in 8.5-8.10.

4.10 *Wires or Rods*—Wires or rods used in the interior of toys shall have their ends finished to avoid potentially hazardous points and burrs, shall be turned back, or shall be covered with smoothly finished protective caps or covers, if they can become accessible after use or reasonably foreseeable abuse. Metal wires or other metal materials used for stiffening or for retention of form in toys shall not fracture to produce a hazardous point, edge, or projection hazard when tested in accordance with 8.12, if the component can be bent through a 60° arc by the applicable maximum force. When applied perpendicularly to the major axis of the component at a point 2 ± 0.05 in. (50 ± 1.3 mm) from the intersection of the component with the main body of the toy or at the end of the component if the component is less than 2 in. (50 mm) long, the maximum force shall be as follows (within a tolerance of ± 0.5 lb (± 0.02 kg)):

10 lbf (45 N)	toys intended for use by children 18 months of age or less
15 lbf (67 N)	toys intended for use by children over 18 but not over 96 months of age

The ends of spokes on toy umbrellas shall be protected. If the protection is removed when tested according to 8.9 (tension test) the ends of the spokes shall be free from sharp edges and sharp points when tested in accordance with 4.7.1 (sharp edge test) and 4.9.1 (sharp point test). Furthermore, if the protective components are removed by the tension test, the spokes shall

have a minimum diameter of 0.08 in. (2 mm) and the ends shall be smooth, rounded, and approximately spherical with no burrs.

4.11 *Nails and Fasteners*—Nails and fasteners shall not present a point, edge, ingestion, or projection hazard. Points of nails or fasteners shall not protrude so as to be accessible. Additional requirements for nails and fasteners used as axles are given in 4.17.

4.12 *Plastic Film*—This requirement is intended to minimize the possibility of asphyxiation hazards that might be caused by thin plastic films. Flexible plastic film bags and flexible plastic sheets used as packaging materials for shelf packages or used with or as part of toys shall be at least 0.00150 in. (0.03810 mm) in average thickness, but the actual thickness of any individual measure shall never be less than 0.00125 in. (0.03175 mm). Alternatively, sheeting with an average thickness of less than 0.00150 in. (0.03810 mm) shall be perforated with defined holes so that a minimum of 1 % of the area has been removed over any area of 1.18×1.18 in. (30×30 mm). The thickness shall be determined using the test method in 8.21. This requirement does not apply to the following:

4.12.1 Shrink film in the form of an over wrap that would normally be destroyed when the package is opened by a consumer.

4.12.2 Bags or plastic film with a minor dimension of 3.94 in. (100 mm) or less. Bag dimensions shall be measured while in the form of a bag, not cut open into a single thickness sheet.

4.13 *Folding Mechanisms and Hinges*—These requirements are intended to eliminate possible crushing, laceration, or pinching hazards that might occur in folding mechanisms and hinges. Examples are the sudden collapse or unexpected motion of a folding mechanism or hinge that produces a scissor

action; and the changing clearances at the hinge line between two hinged portions, such that the gap will admit fingers at any one position of the hinge but not at all positions. These requirements do not relate to the recognized and familiar hazards associated with the changing clearances around the edges of doors or pivoted or hinged sections in toy truck bodies, toy earth moving machinery, and similar toys. Toys shall meet the requirements specified in 4.13.1 and 4.13.2 after they are tested in accordance with 8.5-8.10. Requirements for toy chests are contained in Consumer Safety Specification F834.

4.13.1 *Folding Mechanisms*—Toy furniture and other toys in which a folding mechanism, arm, or bracing is intended or likely to support the weight of a child in normal use shall have a locking device or other means to prevent unexpected or sudden movement or collapse of the product, or have adequate clearance to provide protection for the fingers, hands, and toes from crushing, laceration or pinching hazards in the event of sudden movement or collapse of the product. Examples of products to which these requirements would apply include, but are not limited to, folding mechanisms in toy strollers a child can sit in, toy chairs a child can sit in, or a child sized ironing board. One way to determine if a child can sit in a product is to verify that the seat width would accommodate the hip breadth of a child in the age range for which the product is intended. Examples of products to which these requirements would not apply include, but are not limited to, a doll house sized chair, a doll house sized bed, or an expandable/collapsible sphere.

4.13.1.1 Locking devices or other means to prevent unexpected or sudden movement or collapse of the product shall engage automatically when the product is placed in the manufacturer's recommended use position. During and upon completion of the testing in 8.25.1, the unit shall remain in its recommended use position. The test in 8.25.1 shall not apply to locking devices or other means where the direction of force of the occupant load opposes the direction of collapse of the mechanism.

4.13.1.2 Locking devices shall comply with either of the following:

(1) Each single action device shall require a minimum force of 10 lbf (45 N) to activate the release mechanism when tested in accordance with 8.25.2.

(2) Each double action locking device shall require two distinct and separate actions to release. There are no force requirements for double action locking devices.

4.13.2 *Hinge-Line Clearance*—Toys having a gap or clearance along the hinge line between a stationary portion and a moveable portion that weighs more than ½ lb (0.2 kg) shall be so constructed that, if the accessible gap at the hinge line will admit a 3/16-in. (5-mm) diameter rod, it will also admit a ½-in. (13-mm) diameter rod at all positions of the hinge.

4.14 *Cords, Straps, and Elastics*—These requirements are intended to minimize the potential entanglement and strangulation hazards that might be caused by accessible cords, straps, and elastics. These requirements are applicable before and after use and abuse testing in accordance with 8.5-8.10.

4.14.1 *Cords, Straps, and Elastics in Toys*—Cords or elastics included with or attached to toys intended for children less than 18 months of age (excluding pull toys, see 4.14.3) shall be less than 12 in. (300 mm) long when measured to the maximum length in a free state and under a load of 5 lb (2.25 kg). If cords/straps/elastics or multiple cords/straps/elastics can tangle or form a loop in connection with any part of the toy, including beads or other attachments on the ends of cords/straps/elastics, the loop shall not permit the passage of the head probe (Fig. 10) when tested in accordance with 8.22. Specifically, the loop shall not allow the head probe to be inserted so deep that it admits the base of the probe. The configuration of the loop shall be determined by using all components that make up the loop. For example, the configuration of the loop for the product illustrated in Fig. 11 is comprised of Cord 1, Cord 2, and the toy part.

4.14.1.1 *Cords, Straps, and Elastics Containing a Breakaway Feature*—Cords, straps, and elastics on toys that have loops that admit the base of the head probe shall contain a functional breakaway feature that prevents entanglement by releasing at a force less than 5.0 lbf (22.2 N) when tested in accordance with 8.22.3. The free length of the individual released cord, strap, or elastic should not exceed a maximum length of 12 in. (300 mm). The breakaway feature shall be capable of being reattached without altering the characteristics of the attachment.

4.14.2 *Self Retracting Pull Cords*—Accessible cords used in cord-activated mechanisms in toys intended for use by children under 18 months of age, except monofilament-type cords 1/16 in. (2 mm) or less in diameter, shall not retract more than ¼ in. (6 mm) when a weight of 2 lb (0.9 kg) is attached to the fully extended cord with the cord held vertical and the toy held firmly in the most favorable position for retraction. Monofilament cords, 1/16 in. (2 mm) or less in diameter, shall not retract under a load of 1 lb (0.45 kg) when tested in the manner described above.

4.14.3 *Pull Toys*—Cords, straps, and elastics greater than 12 in. (300 mm) long for pull toys intended for children under 36 months of age shall not be provided with beads or other attachments that could tangle to form a loop.

4.14.4 *Strings and Lines for Flying Devices*—Kite strings and handheld lines over 6 ft (1.8 m) long, attached to flying devices intended for use as playthings, shall have an electric resistance of more than $10^8 \Omega/\text{cm}$ when tested at a relative humidity of not less than 45 % and a temperature of not greater than 75°F (24°C), when measured by a high-voltage, resistance breakdown meter.

4.14.5 *Cords on Toy Bags Intended for Children Up to 18 Months*—Toy bags made of impermeable material with an opening perimeter greater than 14 in. (360 mm) shall not have a drawstring or cord as a means of closing.

4.15 *Stability and Over-Load Requirements:*

4.15.1 *Stability of Ride-On Toys and Toy Seats*—These requirements are intended to minimize unexpected hazards that could be caused by a toy that can tip easily. They take into account the use of the child's legs as stabilizing means and recognize that a child learns instinctively to compensate for inclined positions. The requirements listed in 4.15.2 and 4.15.3

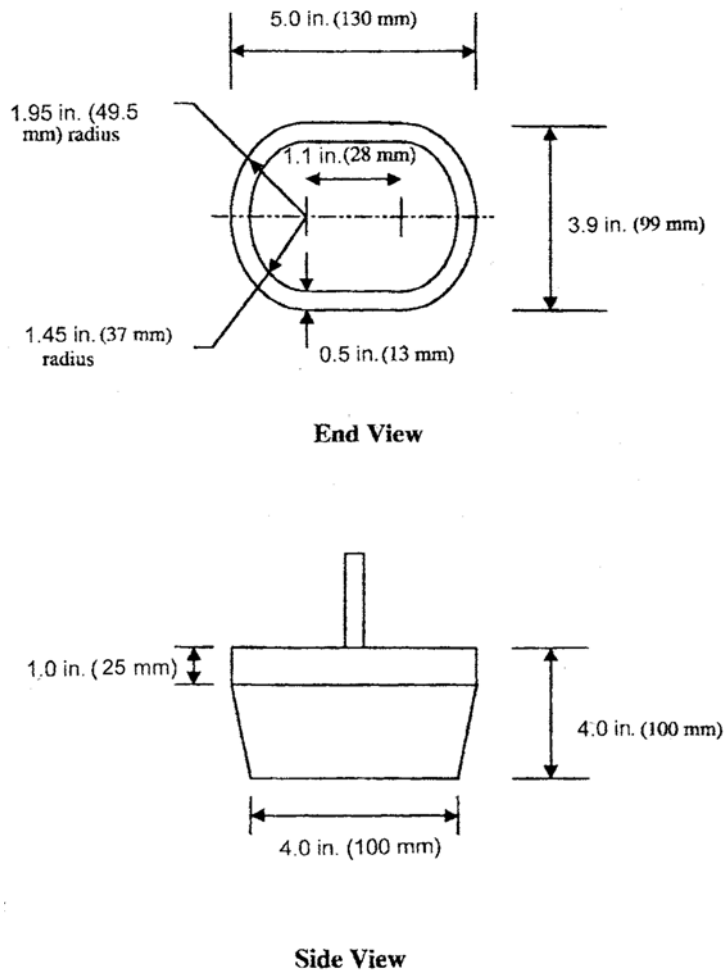

FIG. 10 Head Probe for Cords and Elastics

shall apply to the following classes of toys intended for use by children aged 60 months or less: ride-on toys, with three or more load bearing wheels, such as wagons; ride-on, action-type toys such as hobby horses, rocking toys (for example, horses, cars); and toy seats. Ride-on toys of spherical, cylindrical, or other shape that do not normally have a stable base are not covered by these requirements. The toy shall conform to these requirements after it is tested in accordance with 8.5-8.10.

4.15.2 *Sideways Stability Requirements*—These requirements recognize two types of possible stability hazards: those associated with ride-on toys or toy seats in which the feet can provide stabilization, and those situations in which the feet are restricted by an enclosing structure.

4.15.2.1 *Sideways Stability, Feet Available for Stabilization*—There shall be no sideways stability test for those ride-on toys or toy seats in which the height of the seat from the ground is one third, or less than one third, of the height indicated in Table 3 at the lowest age of the age range for which the ride-on toy or toy seat is intended, and in which the legs of the child are unrestricted in their sideways motion and thus are available for stabilization. (The values given in Table 3 represent the lower of the following two numbers: (1) the fifth percentile group of boys at each age from 1 up to and including 5 years; and (2) the fifth percentile group of girls at

each age from 1 up to and including 5 years.) For those ride-on toys, or toy seats in which the height of the seat from the ground is greater than one third of the height indicated in Table 3 at the lowest age of the age range for which the ride-on toy or toy seat is intended, and in which the legs of the child are unrestricted in their sideways motion and thus are available for stabilization, the toy shall not tip when tested in accordance with 8.15. When the lowest age of the intended age range falls between two ages listed in Table 3, the lower of the two shall be chosen.

4.15.2.2 *Sideways Stability, Feet Unavailable for Stabilization*—If the sideways motion of the feet or legs, or both, is restricted, such as by the enclosed sides of a toy automobile, the ride-on toy or toy seat shall not tip when tested as specified in 8.15, except that the surface shall be inclined 15° to the horizontal.

4.15.3 *Fore and Aft Stability*—This requirement relates to the stability of ride-on toys or toy seats in the forward direction with respect to the child's position, where the child cannot easily use his/her legs for stabilization, and in the backward direction with respect to the child regardless of whether his/her legs are available for stabilization. All ride-on toys or toy seats falling within the scope of 4.15 shall not tip forward or backward when the toy, which shall be loaded with a simulated

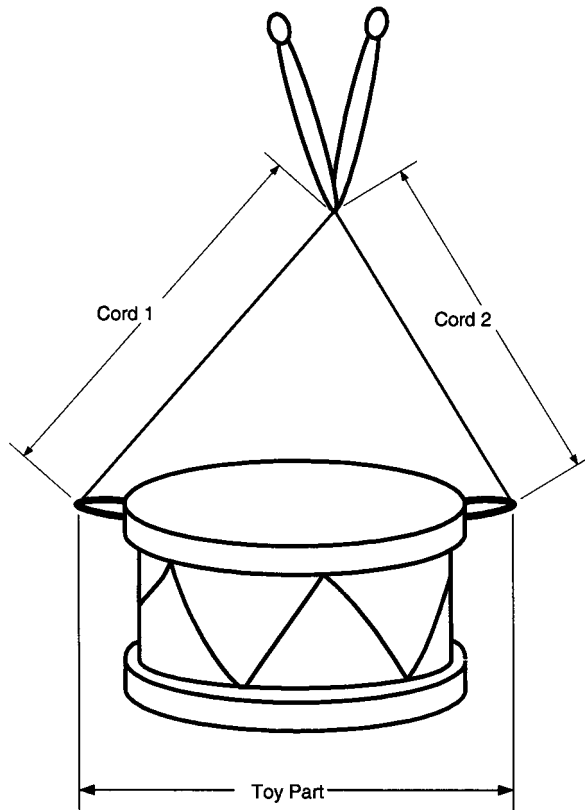

FIG. 11 Loop Example

TABLE 3 Height of Fifth Percentile Children (Values Given for Boys or Girls, Whichever is Lower)

Age, years	Height, in. (cm)
1	27 (69.8)
2	29 (74.4)
3	33 (85.1)
4	37 (93.8)
5	40 (100.5)

child’s weight, is tested both facing down and up the slope using the test method of 8.15, except that the surface shall be inclined 15° to the horizontal. The stability of ride-on toys is to be tested not only with the steering wheels in a forward position, but also at an angle of 45° to the left and to the right of the forward position.

4.15.4 *Stability of Stationary Floor Toys*—This requirement is intended to minimize hazards that might be caused by a toy that tips when a door, drawer, or other movable portion is extended to its fullest travel. Stationary floor toys of greater than 30 in. (760 mm) in height and weighing more than 10 lb (4.5 kg) shall not tip when placed on a 10° incline with all movable portions extended to their fullest travel and facing in the direction of the downslope side. The toy shall conform to this requirement after it is tested in accordance with 8.5-8.10.

4.15.5 *Overload Requirements for Ride-On Toys and Toy Seats*—This requirement is intended to minimize unexpected hazards that could be caused by a toy that is not capable of withstanding an overload. All ride-on toys, toys intended for

use as seats, or toys designed to support all or part of the weight of the child shall support a load applied to the seat, or to other such intended load-bearing components, without collapsing to produce a hazardous condition when tested in accordance with 8.26. Examples of hazardous conditions if collapse occurs would include the following: exposure of hazardous edges, or points, projections, crushing or pinching hazards, and power-driven mechanisms. The toy shall conform to this requirement after being tested in accordance with 8.5 through 8.10.

4.15.6 *Wheeled Ride-on Toys*—Ride-on toys incorporating wheels intended for movement along the ground shall be tested in accordance with the Dynamic Strength Test for Wheeled Ride-ons in 8.20. Wheeled ride-on toys shall be tested after being tested in accordance with 8.5-8.10.

4.16 *Confined Spaces*—The purpose of these requirements is to minimize the possible entrapment of children in toys that form enclosures, such as toy refrigerators, and to prevent possible suffocation in head-enclosing toys such as space helmets. Toys shall meet the requirements listed in 4.16.1-4.16.3 after the toys are tested in accordance with 8.5-8.10. See Consumer Safety Specification F834 for requirements for toy chests.

4.16.1 *Ventilation*—The purpose of these requirements is to minimize the possible entrapment of children in toys that form enclosures, such as toy refrigerators, and to prevent possible suffocation in head-enclosing toys such as space helmets. Any toy made of impermeable material and having a door or lid,

which encloses a continuous volume greater than 1.1 ft³ (0.03 m³) and in which all integral dimensions are 6 in. (150 mm) or more, shall provide one of the following unobstructed ventilation areas:

4.16.1.1 A minimum of two openings each having a total area of at least 1 in.² (650 mm²) placed at least 6 in. (150 mm) apart (see Fig. 12(a)).

4.16.1.2 One opening that is the equivalent of the two 1.0-in.² (650-mm²) openings expanded to include the separation area provided this leaves opening areas of 1.0 in.² (650 mm) on either side of a 6-in. (150-mm) spacing (see Fig. 12(b)). The ventilation openings shall be unobstructed when the toy is placed on the floor in any position and adjacent to two vertical plane surfaces meeting at a 90° angle, so as to simulate the corner of a room. If a permanent partition or bars (two or more), which effectively limit the continuous space by making the largest internal dimension less than 6 in. are used to subdivide a continuous space, the ventilation area shall not be required.

4.16.2 Closures—Closures (such as lids, covers, and doors) to enclosures falling within the scope of 4.16.1 shall not be fitted with automatic locking devices. Closures shall be of a

type that can be opened with a force of 10 lbf (45 N) or less when treated as follows:

4.16.2.1 With the closure in a closed position, apply the force in an outward direction to the inside of the closure perpendicular to the plane of the closure and anywhere within 1 in. (25 mm) from the geometric center of the closure. The force measurement shall be made by means of a force gauge with a calibrated accuracy within ±0.3 lb (0.1 kg) when measuring a force of 10 lb (45 N). The dial of the gauge shall be graduated with its finest division not exceeding 0.2 lb (0.9 N), and the full-scale range shall not exceed 30 lb (130 N).

4.16.3 Toys that Enclose the Head—Toys that enclose the head, such as space helmets, which are made of impermeable material, shall provide means for breathing by the incorporation of unobstructed ventilation areas. The ventilation areas shall consist of a minimum of two holes, with a total of at least 2 in.² (1300 mm²) of ventilation and at least 6 in. (150 mm) between holes.

4.17 Wheels, Tires, and Axles—These requirements are intended to eliminate the possibility of ingestion hazards (as described in 4.6) that might be caused by small wheels or tires that separate during normal use or reasonably foreseeable

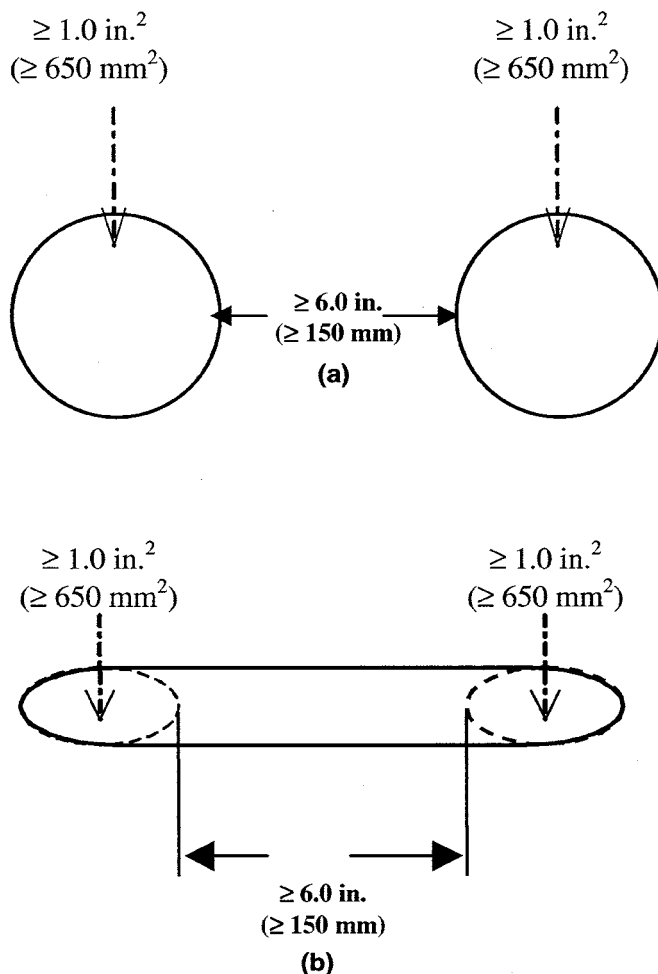

FIG. 12

abuse, as well as laceration or puncture hazards from projecting axles, either on the toy or on wheel assemblies that may be removed from the toy during abuse. The requirements shall apply to transportation wheels on both preassembled and knocked-down toys intended for children aged 96 months or less, except for ingestion hazards from small wheels and axles, which apply to toys intended for children under 36 months of age, as covered in 4.6. In the case of knocked-down toys, the toy shall be tested in the form that it would be assembled by the purchaser, using simple household tools or special tools provided by the manufacturer, if any, or both. After being subjected to the use and abuse tests of 8.5-8.11, wheels, tires, or axles shall not present a laceration, puncture, or ingestion hazard as defined in 3.1.60 and 4.6.1, respectively.

4.18 *Holes, Clearance, and Accessibility of Mechanisms*—These requirements are intended to eliminate possible hazards that may be caused by changing clearances. Toys shall meet these requirements after they are tested in accordance with 8.5-8.10. The different pinch clearance requirements listed in 4.18.1-4.18.6 reflect the different modes of entrapment or pinching that may be encountered.

4.18.1 *Accessible Clearances for Moveable Segments*—This requirement concerns clearances between movable segments on toys intended for children under 96 months only, where the potential for pinching or crushing fingers or other appendages exists. It includes, but is not limited to, wheels and rigid-wheel wells, fenders, or the radial clearance between the wheels and chassis of ride-on toys, or the driven wheels and other parts of toys powered by electrical, spring, or inertial energy. If such accessible clearances admit a 3/16-in. (5-mm) diameter rod, they shall also admit a 1/2-in. (13-mm) diameter rod in order to prevent the trapping of fingers.

4.18.2 *Circular Holes in Rigid Materials*—This requirement is intended to prevent finger entrapment (which may cut off blood circulation) in accessible holes in sheet metal and other rigid material in toys intended for children aged 60 months or less. (Noncircular holes are believed to present no significant hazard of cutting off blood circulation in entrapped fingers.) If an accessible, circular hole in any rigid material less than 0.062 in. (1.58 mm) in thickness can admit a 1/4-in. (6-mm) diameter rod to a depth of 3/8 in. (10 mm) or greater, it shall also admit a 1/2-in. (13-mm) diameter rod.

4.18.3 *Chains and Belts*—These requirements are to prevent finger crushing through entrapment between links of supporting chains or between chains and sprockets or pulleys and belts.

4.18.3.1 *Supporting Chains*—Chains in toys that support the weight of a child, such as hanging seats or similar indoor devices, intended for children 36 months or less in age, shall be shielded if the chain is accessible and if a 0.19-in. (5-mm) diameter rod can be inserted between two links, as in Fig. 13, with the chain in slack configuration.

4.18.3.2 *Chains or Belts for Ride-On Toys*—Power transmission chains and belts in ride-on toys shall be shielded.

4.18.4 *Inaccessibility of Mechanisms*—Clockwork, battery-operated, inertial, or other power-driven mechanisms in toys intended for children aged 60 months or less shall not have any accessible part of the mechanism present a pinch or laceration hazard. (For circular holes, also see the requirement under 4.18.2.)

4.18.5 *Winding Keys*—This requirement is to prevent the pinching or laceration of fingers by entrapment between the key and body of the toy. It applies to toys intended for children under 36 months of age that use winding keys that rotate as the mechanism unwinds. This requirement applies to keys with flat plates attached to the stem and that protrude from a rigid surface; the requirement does not apply to those circular knobs to which the torque is applied. If the clearance between the flukes of the key and body of the toy will admit a 0.25-in. (6-mm) diameter rod, it shall also admit a 0.5-in. (13-mm) diameter rod at all positions of the key. For keys covered by this requirement, there shall be no opening in the flukes of the key that can admit a 0.19-in. (5-mm) diameter rod.

4.18.6 *Coil Springs*—These requirements are intended to prevent the pinching or crushing of fingers or toes by toys containing springs. Coil springs (either compression or extension) that form part of a component that carries the weight of a child shall be shielded so as to prevent access during use or reasonably foreseeable abuse unless either of the following occurs:

4.18.6.1 A 0.12-in. (3-mm) diameter rod cannot be inserted freely; or

4.18.6.2 A 0.25-in. (6-mm) diameter rod can be inserted freely between the adjacent coils at all points in the action cycle when the spring is subjected first to a weight of 3 lb (1.4 kg) and then to a weight of 70 lb (32 kg).

4.19 *Simulated Protective Devices (such as helmets, hats, and goggles)*—These requirements are intended to minimize hazards that might be caused, for example, by goggles or space helmets if the material from which they are constructed fails; or by toys that simulate protective devices such as football helmets and pads, if the wearer uses the article as a real protective device rather than as a toy. The toy shall conform to the requirements listed in 4.19.1 and 4.19.2 after testing in accordance with 8.7.4 and 8.8 through 8.10.

4.19.1 *Eye Protection*—All rigid toys that cover the face, such as goggles, space helmets, or face shields, shall be constructed of impact-resistant material that will not have sharp edges, sharp points, or loose parts that could enter the eye before or after being tested in accordance with 8.5-8.10. This applies to items with cutout eye holes as well as items that cover the eyes.

4.19.2 Toys that simulate safety protective devices (examples include, but are not limited to, construction helmets and

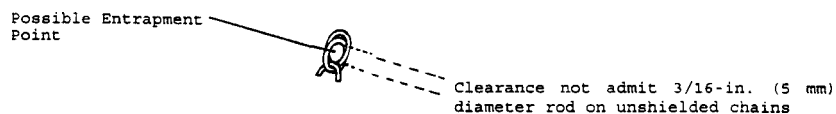

FIG. 13 Clearance for Chain Links

sports helmets) and their packages shall be labeled clearly in accordance with 5.9 to warn the purchaser that they are not safety protective devices.

4.20 *Pacifiers*—Infant pacifiers shall conform to the safety requirements as specified in 16 CFR 1511. Illustrations of the pacifier test fixture are shown in Fig. 14.

4.20.1 Pacifiers with rubber nipples shall conform to the nitrosamine levels as specified in Specification F1313. This specification states that a test sample of nipples, drawn from a standard production lot, shall not contain more than 10 ppb in each of three aliquots of any one nitrosamine. In addition, the total nitrosamines of the sample shall not exceed 20 ppb.

4.20.2 Toy pacifiers attached to, or sold with, toys intended for children under 36 months of age shall comply with the requirements outlined in 4.6.1 of this specification (small objects), and either conform to the requirements of 16 CFR 1511 or have a nipple length no longer than 0.63 in. (16 mm). This measurement shall be taken from the nipple side of the shield to the end of the nipple.

4.21 *Projectile Toys*—These requirements relate to certain, but not all, potential, unexpected hazards that might be caused by projectile firing toys and by the firing of improvised projectiles from such toys. Certain well-recognized hazards that are inherent in traditional toys such as slingshots and darts are not covered by these requirements. The discharge mechanism as well as the projectile shall conform to the requirements specified in this section after testing in accordance with the appropriate test methods described in 8.5-8.10 and 8.14.

4.21.1 These requirements apply to toys that are intended to launch projectiles into free flight by means of a discharge mechanism in which the kinetic energy of the projectile is determined by the toy and not by the user.

4.21.1.1 No projectile intended to be fired from a toy shall have any sharp edges, sharp points, or small parts that would fit within the cylinder shown in Fig. 3.

4.21.1.2 No rigid projectile fired from a toy shall have a tip radius less than 0.08 in. (2 mm).

4.21.1.3 Any rigid projectile fired from a toy that has a kinetic energy that exceeds 0.08 J (as determined by 8.14.1) shall have an impact surface(s) of a resilient material.

4.21.1.4 Any protective tip shall either (1) not be detached from the projectile when subjected to the torque and tension tests described in 8.8 and 8.9, or (2) if the protective tip does become detached during the test at less than the specified torque or tension, or both, the projectile shall not be able to be launched from the provided launcher. Additionally, the protective tip shall not produce or reveal hazardous points or edges when fired into a solid object, in accordance with the test methods described in 8.14.4.

4.21.1.5 The aforementioned requirements shall not apply to any discharge mechanism incapable of storing energy independent of the user, or intended to propel a ground-based vehicular toy along a track or other surface, or when the projectile is inaccessible to a child when it leaves the discharge mechanism, for example, bagatelle or pinball machines.

4.21.2 *Discharge Mechanisms*—Discharge mechanisms shall be unable to discharge potentially hazardous improvised projectiles such as pencils or pebbles without modification by the user.

4.21.3 Any arrow shall have a protective tip that complies with 4.21.1.4.

4.22 *Teethers and Teething Toys*—These requirements are intended to address a potential impaction hazard associated with teethers. These requirements are applicable before and after use and abuse testing in accordance with Section 8.

4.22.1 Teethers and teething toys shall conform to the dimensional requirements for infant rattles as specified in 16 CFR 1510. Illustrations of a rattle test fixture are shown in Fig. 15. A teether shall meet this requirement when tested under the force only of its own weight and in a noncompressed state.

4.22.2 In addition, teethers and teething toys incorporating nearly spherical, hemispherical, or circular flared ends shall be designed so that such ends are not capable of entering and

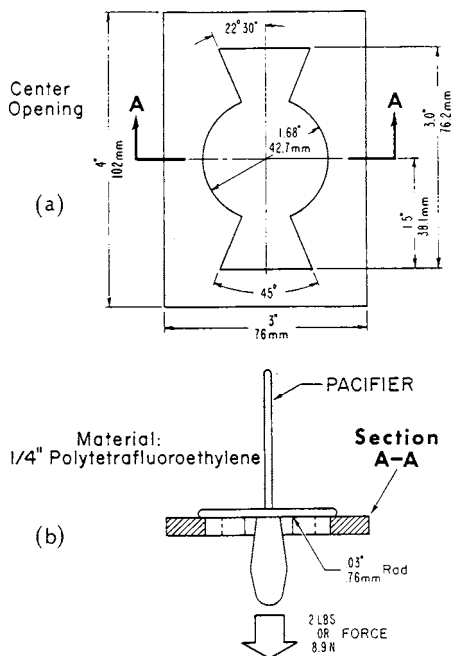

FIG. 14 Pacifier Test Fixture

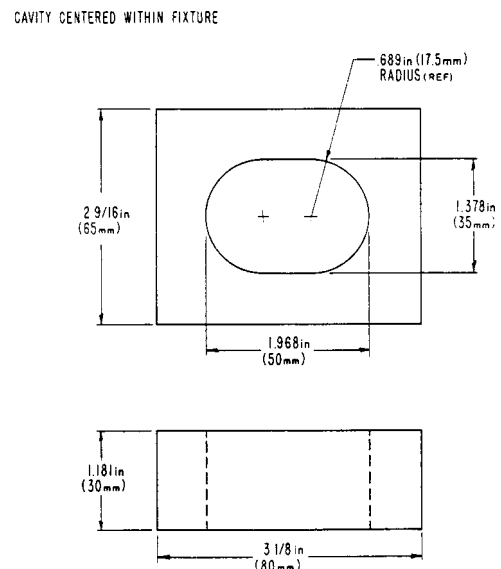

FIG. 15 Rattle Test Fixture

penetrating to the full depth of the cavity in the supplemental test fixture shown in Fig. 16. A teether shall meet this requirement when tested under the force only of its own weight and in a noncompressed state.

4.22.3 *Exclusion*—The requirements of 4.22.1 and 4.22.2 shall not apply to the following:

(1) Teething toys that are composed of liquid-filled beads that are attached to form a ring or beads that are threaded on a flexible cord or string.

(2) Soft-filled (stuffed) teething toys or soft-filled parts or parts of fabric.

(3) Rigid components having a major dimension equal to or less than 1.2 in. (30 mm) contained within soft-filled teething toys.

4.23 *Rattles*—Infant rattles shall conform to the safety requirements as specified in 16 CFR 1510. Illustrations of a rattle test fixture are shown in Fig. 15.

4.23.1 In addition to meeting the requirements of 16 CFR 1510, rigid rattles incorporating nearly spherical, hemispherical, or circular flared ends shall be designed so that such ends are not capable of entering and penetrating to the full depth of the cavity in the supplemental test fixture illustrated in Fig. 16. A rattle shall meet this requirement when tested under the force only of its own weight and in a noncompressed state. These

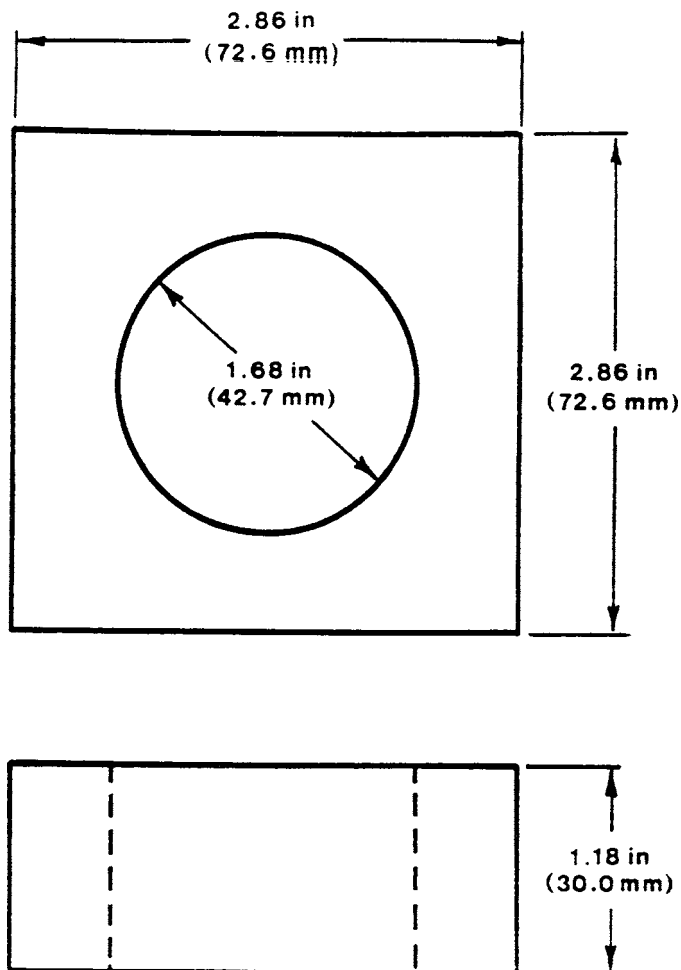

FIG. 16 Supplemental Test Fixture for Rattles, Squeeze Toys, and Teethers

requirements are applicable before and after use and abuse testing in accordance with Section 8.

4.23.2 *Exclusion*—The requirements of 4.23 and 4.23.1 shall not apply to the following:

(1) Soft-filled (stuffed) rattles or soft-filled parts or parts of fabric.

(2) Rigid components having a major dimension equal to or less than 1.2 in. (30 mm) contained within soft-filled rattles.

4.24 *Squeeze Toys*—These requirements are intended to address a potential impaction hazard associated with squeeze toys intended for children under the age of 18 months. These requirements are applicable before and after use and abuse testing in accordance with Section 8.

4.24.1 Squeeze toys shall conform to the dimensional requirements for rattles as specified in 16 CFR 1510. Illustrations of a rattle test fixture are presented in Fig. 15. A squeeze toy shall meet these requirements when tested under the force only of its own weight and in a noncompressed state.

4.24.2 In addition, squeeze toys incorporating nearly spherical, hemispherical, or circular flared ends shall be designed so that such ends are not capable of entering and penetrating to the full depth of the cavity in the supplemental test fixture shown in Fig. 16. A squeeze toy shall meet these requirements when tested under the force only of its own weight and in a noncompressed state.

4.24.3 *Exclusion*—The requirements of 4.24.1 and 4.24.2 shall not apply to the following:

(1) Soft-filled (stuffed) squeeze toys or soft-filled parts or parts of fabric.

(2) Rigid components having a major dimension equal to or less than 1.2 in. (30 mm) contained within soft-filled squeeze toys.

4.25 *Battery-Operated Toys*—These requirements are intended to address potential risks of injury associated with battery usage in toys intended for use by children (for example, battery overheating, leakage, explosion and fire, and choking on or swallowing batteries). Both non-rechargeable and rechargeable batteries are subject to these requirements. Battery-operated toys shall conform to the requirements specified in this section after testing in accordance with the appropriate test methods described in 8.5-8.12. For purposes of ensuring compliance with these requirements, fresh alkaline batteries that meet the dimensional requirements of the latest revision of ANSI C18.1 or the latest revision of IEC 60086-2 shall be selected for test purposes. If another battery chemistry is specifically required for use in the toy by the manufacturer, testing shall be repeated using that type of battery. When rechargeable batteries are specified by the manufacturer, fully recharged batteries shall be used for testing purposes.

4.25.1 The toy shall be marked permanently on the battery compartment or on the area immediately adjacent to the battery compartment to show the correct battery polarity using the polarity symbols “+” and “-”. Additional markings located on the toy or in the instructions must indicate the correct battery size and voltage. These markings are not required for non-replaceable batteries or for rechargeable battery packs that, by

design, can only be inserted in the correct orientation. Battery compartments for button cell batteries are not subject to this requirement.

NOTE 5—The battery compartment door is considered part of the battery compartment.

4.25.1.1 Toys containing non-replaceable batteries shall be labeled in accordance with 5.15.

4.25.2 The maximum allowable direct current potential between any two accessible electrical points is 24 V nominal.

4.25.3 Battery-operated toys shall be designed so that it is not possible to charge any non-rechargeable battery. This can be achieved through physical design of the battery compartment or through the use of an appropriate electrical circuit design. This applies to situations in which a battery may be installed incorrectly (reversed) or in which a battery charger may be applied to a toy containing non-rechargeable batteries, or both. This section does not apply to circuits having one or two non-rechargeable batteries as the only source of power.

4.25.3.1 Toys having a circuit powered only by button cell type batteries are not subject to this requirement.

4.25.4 For toys intended for children less than 3 years old, all batteries shall not be accessible before or after testing in accordance with 8.5-8.10, without the use of a coin, screwdriver, or other common household tool. Testing is performed using the recommended batteries installed.

4.25.5 For all toys, batteries that fit completely within the small parts test cylinder shown in Fig. 3 shall not be accessible, before or after testing in accordance with 8.5-8.10, without the use of a coin, screwdriver, or other common household tool. Testing is performed using the recommended batteries installed.

4.25.6 Batteries of different types or capacities shall not be mixed within any single electrical circuit. In applications requiring more than one type or capacity of battery to provide different functions or in applications requiring the combination of alternating current and non-rechargeable batteries, each circuit shall be isolated electrically to prevent current from flowing between the individual circuits.

4.25.7 The surfaces of the batteries shall not achieve temperatures exceeding 71°C.

4.25.7.1 This requirement is applicable for all battery-operated toys during normal use conditions. In addition, battery-operated toys intended for children 96 months or less shall meet this requirement after reasonably foreseeable abuse.

4.25.7.2 If external moving parts of the toy that are mechanically linked to the motor can be stalled by the user, test for a stalled motor condition according to the procedures of 8.17 to determine conformance with the temperature limits.

4.25.8 No condition shall occur that would cause the toy to fail the temperature requirements of 4.25.7 or present a combustion hazard as described in 4.25.

4.25.9 Battery-operated toys shall meet the requirements of 6.5 for instructions on safe battery usage. Toys which use non-replaceable batteries as the only source of power are not subject to 6.5.

4.25.10 *Battery-Powered Ride-On Toys*—These requirements cover wheeled ride-on toys, not intended for streets or

roadways, using a battery power source that is capable of delivering at least 8 amps into any variable resistor load for at least one minute.

4.25.10.1 The maximum temperature measured on the insulation of any conductor shall not exceed the temperature rating of the material (third party test laboratory rating) when tested in accordance with 8.18.2.

4.25.10.2 Battery-powered ride-on toys shall not present a risk of fire when tested in accordance with the stalled motor test of 8.18.3.

4.25.10.3 A battery-powered ride-on toy designed with a wiring system that has a user replaceable device (fuse type) for the primary circuit protection or a wiring system with user resettable primary circuit protection (manual reset fuse) shall not actuate (open or trip) when tested in accordance with the nuisance tripping test of 8.18.4.

4.25.10.4 Switches used in battery-powered ride-on toys.

(1) Polymeric materials in switches used in battery-powered ride-on toys that are used to support current-carrying parts shall carry a minimum flame rating of UL-94 V-0 or have a glow wire ignition rating of 750°C. Note: This requirement does not apply to switches used in low-power circuits. A low-power circuit is defined as one using an effective battery power source that is not capable of delivering at least 8 amps into any variable resistor load for at least one minute.

(2) The switch body shall not result in a short-circuit condition when subjected to the switch endurance test and overload tests of 8.18.5.

(3) The switch shall not fail in a mode that could cause the vehicle to run continuously (switch stuck in the “on” position) when subjected to the endurance test and the overload test in 8.18.5.

4.25.10.5 User replaceable circuit protection devices in battery-powered ride-on toys.

(1) User replaceable circuit protection devices used in battery-powered ride-on toys shall be listed, recognized or certified by an independent laboratory.

(2) All circuit protection devices used in battery-powered ride-on toys intended to be replaced by the user shall be replaceable only with the use of a tool or by a design which does not easily allow tampering such as a design requiring excessive force to open.

4.25.10.6 Batteries, as described in 4.25.10, and battery chargers.

(1) Battery connectors must be constructed of material with a V-0 flame rating or have a glow wire ignition rating of 750°C.

(2) The battery charging system shall not present a risk of fire due to a short-circuit condition applied to any point in the length of a charger/battery interconnecting cable when tested in accordance with 8.18.7.

(3) During charging, battery-charging voltages shall not exceed the recommended charging voltages when tested in accordance with 8.18.6.

(4) Battery chargers must be certified to the appropriate current national standard, for example UL, CSA, or equivalent standards body.

4.25.10.7 Wiring connected to the main/motor battery shall be short-circuit protected and shall not present the risk of fire when tested in accordance with 8.18.7.

4.25.10.8 Strain relief shall be provided to prevent mechanical stress on wires entering a connector block during routine maintenance such as battery charging, and tested in accordance with 8.18.8.

4.25.10.9 Battery-powered ride-on toys shall comply with the requirements in 5.15.1 for safety labeling, 6.5.3 for additional instructional literature, and 7.2 for required producer's markings.

4.26 *Toys Intended to be Attached to a Crib or Playpen*—These requirements are intended to minimize entanglement or strangulation hazards that might be caused by toys intended to be attached to a crib or playpen (see also 4.14).

4.26.1 *Protrusions*—Toys attached to a crib or playpen in the manner prescribed by the manufacturer's instructions shall not have hazardous protrusions that could contribute to entanglement injury. This requirement is applicable before and after use and abuse testing in accordance with 8.5-8.10. Design guidelines are provided in Annex A3.

4.26.2 *Crib Mobiles*—Crib mobiles shall comply with the requirements listed in 5.6 for safety labeling and 6.3 for instructional literature.

4.26.3 *Crib Gyms*—Crib gyms, including crib exercisers and similar toys intended to be strung across a crib or playpen, shall comply with the requirements listed in 5.5 for safety labeling and 6.2 for instructional literature.

4.27 *Stuffed and Beanbag-Type Toys*—Stuffed and beanbag-type toys shall meet the applicable requirements of this specification after being tested in accordance with 8.9.1.

4.28 *Stroller and Carriage Toys*—Stroller and carriage toys shall comply with the requirements for safety labeling in 5.7.

4.29 *Art Materials*—The purpose of this requirement is to minimize the potential risks associated with the use of art materials that present chronic health hazards.

4.29.1 Toys and components of toys that fall within the definition of art material as found in 16 CFR 1500.14 (b) (8) shall meet the requirements for toxicological review by a U.S. board-certified toxicologist. The protocol used to evaluate the art materials must be filed with the Consumer Product Safety Commission (CPSC), and the list of ingredients must also be filed with the commission if the material is or contains a chronically hazardous substance.

4.29.2 Toys and components of toys that are art materials and are determined to contain hazardous materials must have appropriate warnings as defined in the Federal regulations and as noted in 5.13 of this specification. Items that do not contain hazardous materials must also be labeled as to their conformity.

4.29.3 Toys and components of toys that have been determined to pose a chronic health hazard and require warnings are not suitable for use by children who are in pre-kindergarten, or grades one through six.

4.30 *Toy Gun Marking*—This requirement is intended to minimize the potential for a toy gun to be mistaken for a real firearm.

4.30.1 This requirement applies to all toy, look-alike, and imitation firearms which have the general appearance, shape,

or configuration, or combination thereof, of a firearm. This includes, but is not limited to, nonfunctional guns, water guns, air soft guns, cap guns, light emitting guns, and guns with an opening to eject any nonmetallic projectile.

4.30.2 This requirement does not apply to the following types of guns:

4.30.2.1 Futuristic toy guns that do not have the general appearance, shape, or configuration, or combination thereof, of any firearm.

4.30.2.2 Nonfiring collector replica antique firearms that look authentic and may be a scale model but are not intended as toys.

4.30.2.3 Traditional B-B guns, paint ball guns, or pellet guns that expel a projectile through the force of compressed air, compressed gas, or mechanical spring action, or combination thereof.

4.30.2.4 Decorative, ornamental, and miniature objects having the appearance, shape, or configuration, or combination thereof, of a firearm provided that the objects measure no more than 1.50 in. (38 mm) in height by 2.75 in. (70 mm) in length, with the length measurement excluding any gun stock length measurement. This includes items intended to be displayed on a desk or worn on bracelets, necklaces, key chains, etc.

4.30.3 Items subject to this requirement must be marked or manufactured, or both, in any one of the following ways. The marking must be permanent and must remain in place after being tested in accordance with 8.5-8.10. The word "permanent" excludes the use of ordinary paint or labels for the purposes of this section. The "blaze orange" color referred to in 4.30.3.1 and 4.30.3.2 is Federal Standard 595a, Color 12199.

4.30.3.1 A blaze orange plug, or brighter orange colored plug, affixed into the muzzle end of the barrel as an integral part of the toy. The plug shall not be recessed more than 0.25 in. (6 mm) from the muzzle end of the barrel.

4.30.3.2 A blaze orange band, or brighter orange colored band, covering the circumference of the muzzle end of the barrel for a distance of at least 0.25 in. (6 mm).

4.30.3.3 Coloration of the entire exterior surface of the toy in white, bright red, bright orange, bright yellow, bright green, bright blue, bright pink, or bright purple, either individually or as the predominant color in combination with any other color in any pattern.

4.31 *Balloons*—Packages containing latex balloons and toys or games containing latex balloons shall comply with the labeling requirements of 16 CFR 1500.19. Labeling statements for balloons are contained in 5.11.5 of this specification.

4.32 *Certain Toys with Nearly Spherical Ends*—These requirements are intended to address a potential impaction hazard associated with nearly¹³ spherical, hemispherical, circular flared or dome shaped ends on toys or components of toys.

4.32.1 Nearly spherical, hemispherical, circular flared, or dome-shaped ends of toys or components of toys must not be capable of penetrating the full depth of the cavity of the supplemental test fixture shown in Fig. 16 when tested under

¹³ The term "nearly" is used here, consistent with the long standing and successful squeeze toy requirement.

the force only of their own weight and in a noncompressed state. This requirement applies to toys if they meet all the following criteria:

4.32.1.1 The toy is intended for children up to the age of 18 months.

4.32.1.2 The toy or component containing the nearly spherical end weighs less than 1.1 lb (0.5 kg).

4.32.1.3 The nearly spherical, hemispherical, circular flared or dome shaped end adjoins a shaft, handle or support that has a smaller cross section.¹⁴

(1) *Exclusion*—The requirement of 4.32.1 does not apply to softfilled (stuffed) toys or softfilled parts of toys or parts entirely of fabric.

4.32.2 Nearly spherical, hemispherical, or dome-shaped ends of toy fasteners (for example, nails, bolts, screws, pegs) (see Fig. 17) must not be capable of penetrating the full depth of the cavity of the supplemental test fixture shown in Fig. 16 when tested under the force only of their own weight and in a noncompressed state. This requirement of 4.32.2 applies to toy fasteners if they meet all the following criteria:

4.32.2.1 They are intended for children aged at least 18 months but less than 48 months of age.

4.32.2.2 They have an overall length of 2.25 in. (57.1 mm) or greater.

4.32.2.3 Their nearly spherical, hemispherical or domed ends have a diameter equal to or greater than 0.6 in. (15 mm).

4.32.2.4 The distance from the apex of the fastener to the undercut is 1.75 in. (44.4 mm) or less as shown in Fig. 18.

(1) *Exclusions*—The requirement of 4.32.2 does not apply to the following toy fasteners:

(a) Softfilled (stuffed) or fabric fasteners,

(b) Fasteners with nonrigid ends, and

(c) Fasteners tethered to a toy where the weight of the combined toy/fastener is more than 1.1 lb (0.5 kg) and the length of the tether is less than 12 in. (300 mm).

4.32.3 *Preschool Play Figures*—This requirement is intended to address the potential choking/obstruction hazard associated with certain preschool figures intended for children under three years of age. The characteristics that distinguish toy figures falling within the scope of this requirement include: (1) a round, spherical, or hemispherical end with tapered neck attached to a simple cylindrical shape without appendages, and (2) an overall length not exceeding 2.5 in. (64 mm) (see examples in Fig. 19). This includes figures with added or molded features such as hats or hair, which retain the rounded shape of the end.

4.32.3.1 Preschool play figures intended for children under three years of age shall be designed so that their rounded ends are not capable of entering and penetrating to the full depth of

¹⁴ This sentence attempts to clarify that the requirements only apply to the nearly spherical end and not to nonspherical areas of the toy or component. In addition, the term “adjoins” replaces the term “attached” as the handle and spherical end may be all part of the same molded piece.

the cavity in the supplemental test fixture illustrated in Fig. 16. Test the play figure under the force of its own weight.

4.32.3.2 *Exclusion*—The requirement of 4.32.3.1 shall not apply to soft play figures made of textiles.

4.33 *Marbles*—Marbles shall comply with the labeling requirements of 16 CFR 1500.19. Labeling statements for marbles are contained in 5.11.4 of this specification.

4.33.1 Toys and games intended for children at least 3 years of age but less than 8 years of age that contain a marble shall comply with the labeling requirements 16 CFR 1500.19. Applicable labeling statements are contained in 5.11.4.1 of this specification.

4.34 *Balls*:

4.34.1 Balls intended for children under 36 months of age are subject to the requirements of 16 CFR 1500.18 (a)(17). A loose ball in toys intended for children under 36 months of age shall not, under the influence of its own weight and without compression, pass entirely through the template shown in Fig. 20. A ball which does pass through the template is determined to be a “small ball.”

4.34.2 Toys intended for children at least 3 years old but less than 8 years of age that contain a loose small ball are subject to the requirements of 16 CFR 1500.19. Applicable labeling statements are contained in 5.11.3 of this specification.

4.35 *Pompoms*—These requirements are intended to address choking hazards associated with pompoms on toys intended for children under three years of age that detach during 8.16. Pompoms detached during 8.16 must not pass entirely through the 1.75-in. (44.5-mm) test fixture (see Fig. 20) under their own weight. Any components, pieces, or individual strands of the pompom that are liberated during the torque and tension tests should not be subject to this test. Test the pompoms by putting the free ends of fiber into the gauge.

4.36 *Hemispheric-Shaped Objects*—These requirements apply to toy cup-, bowl-, or one-half egg-shaped objects having a nearly round, oval, or elliptical opening with the minor and major inner dimensions between 2.5 in. (64 mm) and 4.0 in. (102 mm), a volume of less than 6.0 oz (177 mL), a depth greater than 0.5 in. (13 mm), and intended for children under 3 years of age. The following are exempt from this requirement:

4.36.1 Objects intended for drinking (for example, tea cups).

4.36.2 Objects intended to hold liquids in products appropriate for children at least 2 years old (for example, pots and pans).

4.36.3 Containers that must be airtight so the contents can maintain their functional integrity (for example, modeling clay containers.)

4.36.4 Non-detachable (as determined by testing in accordance with 8.6-8.10 of this specification) components of larger products (for example, bowl-shaped smoke stack that is permanently attached to a toy train or a swimming pool that is molded into a larger toy playscape).

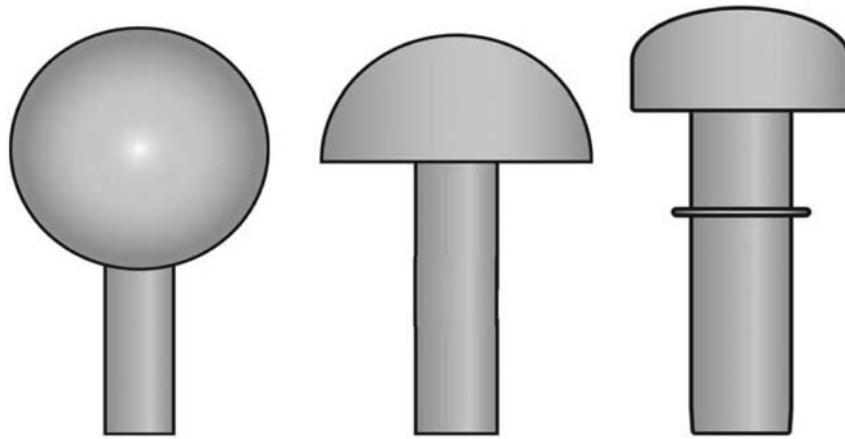

Domed ends, with and without small flat in the center

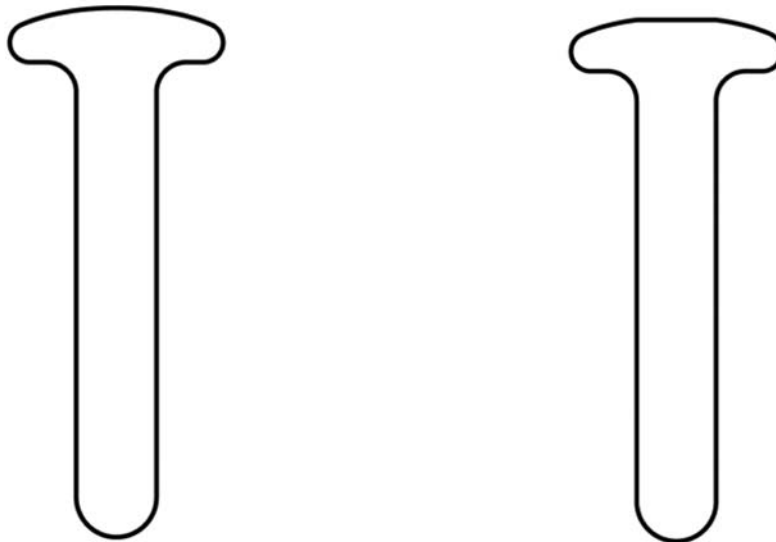

FIG. 17 Examples of Hemispherical and Domed Ends

4.36.5 Containers that are part of the retail package intended to be discarded once the toy is removed from the package.

4.36.6 *Performance Requirements*—Cup/bowl/one-half egg-shaped objects must have, as a minimum, one of the following characteristics (*a*, *b*, *c*, *d*, or *e*). For purposes of these requirements, unless otherwise specified, an opening is defined as a hole of any shape with a minor dimension of 0.080 in. (2 mm). These requirements apply before and after testing in accordance with 8.6-8.10 of this specification.

(*a*) Have at least two openings that are a minimum of 0.5 in. (13 mm) from the rim as measured along the outside contour.

(1) If the openings are placed in the base of the object, at least two of the openings must be a minimum of 0.5 in. (13 mm) apart. (See Fig. 21.)

(2) If the openings are not placed in the base of the object, at least two of the openings must be placed at least 30° but not more than 150° apart. (See Fig. 22.)

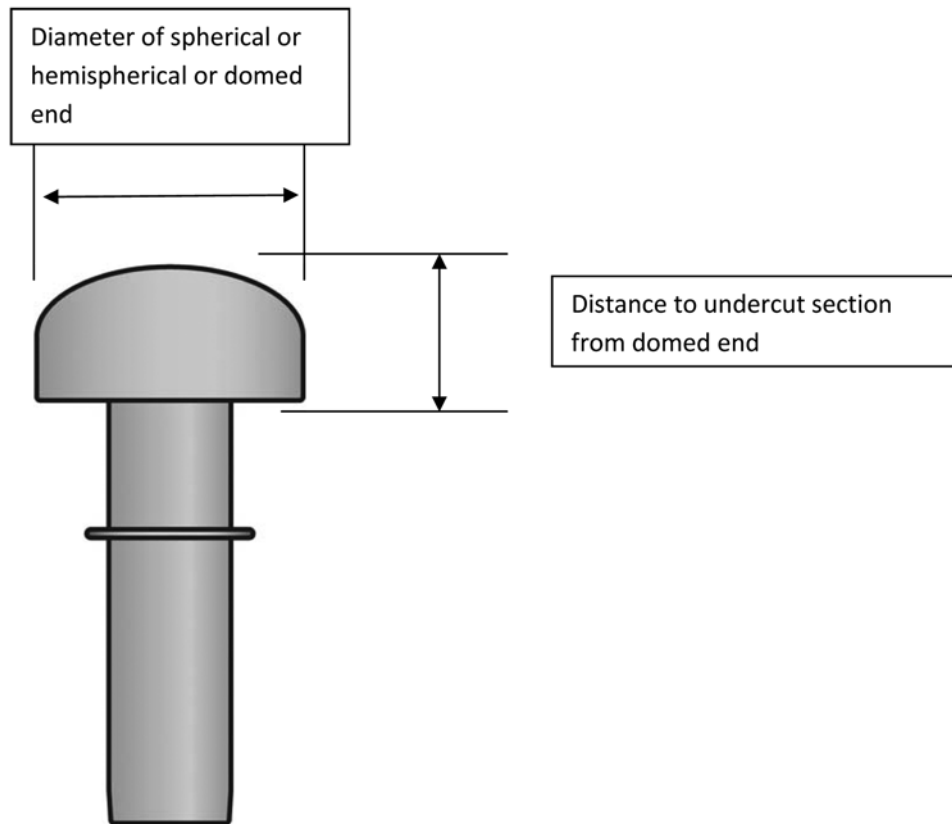

FIG. 18 Undercut and Diameter

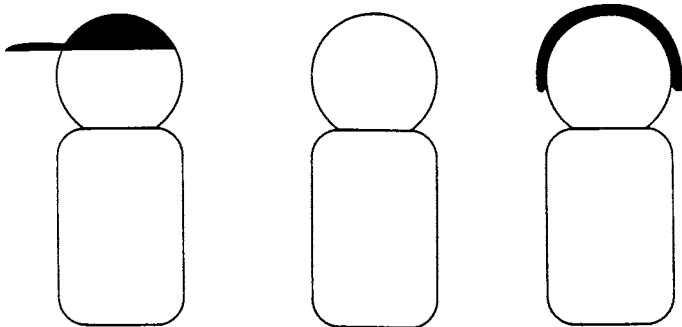

FIG. 19 Examples of Preschool Play Figures

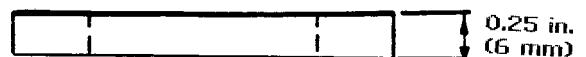
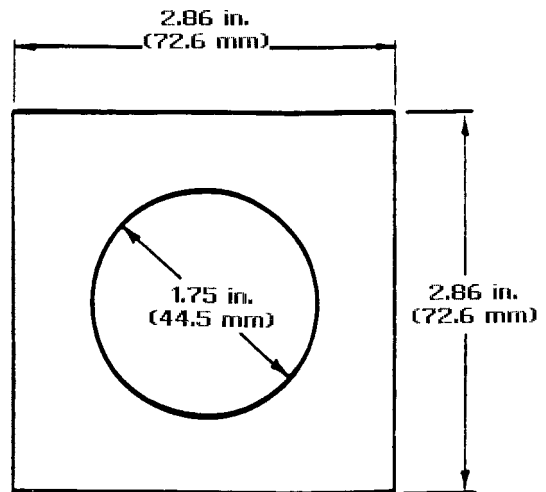

FIG. 20 Test Fixture for Small Balls

(b) The plane of the open end of the cup shape shall be interrupted at the center by some type of divider that extends to 0.25 in. (6 mm) or less from the plane of the open end of the cup. (See Fig. 23 for an example.)

(c) Have three openings that are at least 100° apart, located between 0.25 in. (6 mm) and 0.5 in. (13 mm) from the rim as measured along the outside contour.

(d) Have a repeating scalloped edge pattern around the entire rim. The maximum distance between center lines of adjacent peaks shall be 1 in. (25 mm) and the minimum depth shall be 0.25 in. (6 mm). (See Fig. 24 for examples of scalloped edge patterns.)

(e) Have an opening with a minor dimension of at least 0.66 in. (17 mm) located anywhere in the base or in the side wall of the object. If the opening is located in the sidewall of

the object, the edge of the opening must be at least 0.5 in. (13 mm) from the rim as measured along the outside contour.

4.37 Yo Yo Elastic Tether Toys—These requirements are intended to address potential strangulation hazards associated with yo yo elastic tether toys intended for children 36 months and over.

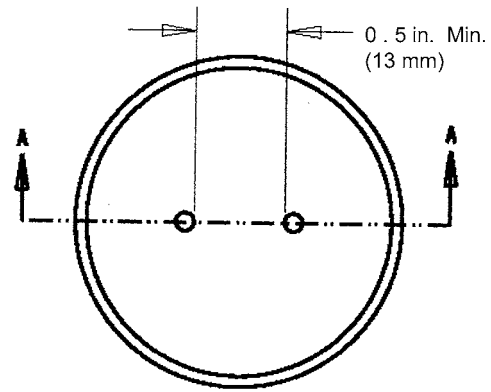
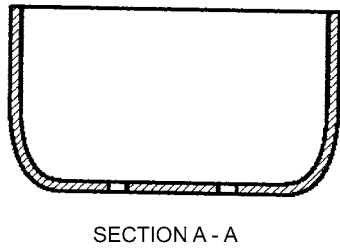

FIG. 21 Openings in Base of Bowl

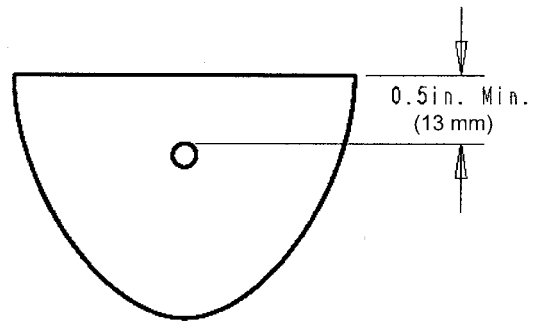
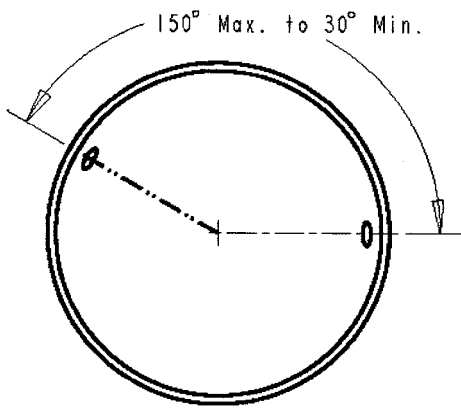

FIG. 22 Opening Placement

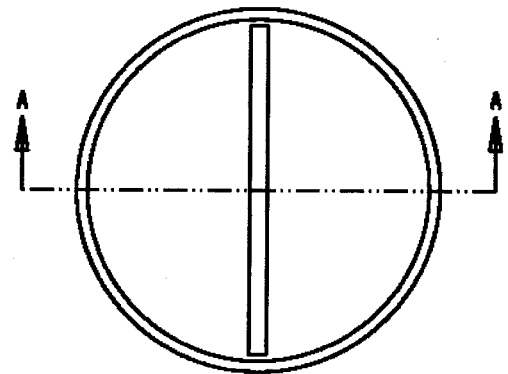
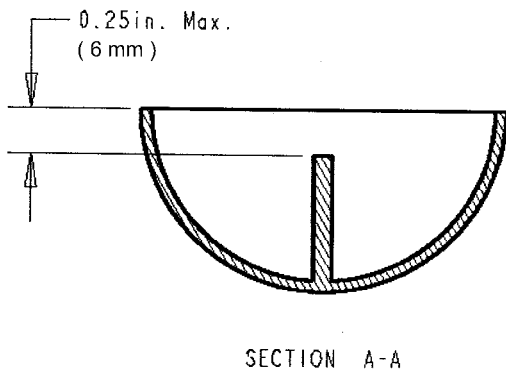

FIG. 23 Rib Through Cup Center

4.37.1 Toys with an end mass greater than 0.02 kg (0.044 lb) shall have a tether length less than 50 cm (20 in.) measured when the toy is rotating at any speed up to a maximum speed of 80 r/min. Testing shall be conducted in accordance with 8.23.

4.37.2 Exemptions:

- (1) Paddle balls.
- (2) Sports balls with wrist or ankle straps longer than 70 cm (27.6 in.) intended to be kicked or thrown and returned to the

user. The length of the strap shall be measured when the product is placed on a horizontal surface with no load.

4.38 Magnets—This requirement is intended to address ingestion hazards associated with toys intended for children up to 14 years of age that contain a hazardous magnet. This requirement does not apply to magnets used in motors, relays, speakers, electrical components, and similar devices where the magnetic properties are not part of the play pattern of the toy.

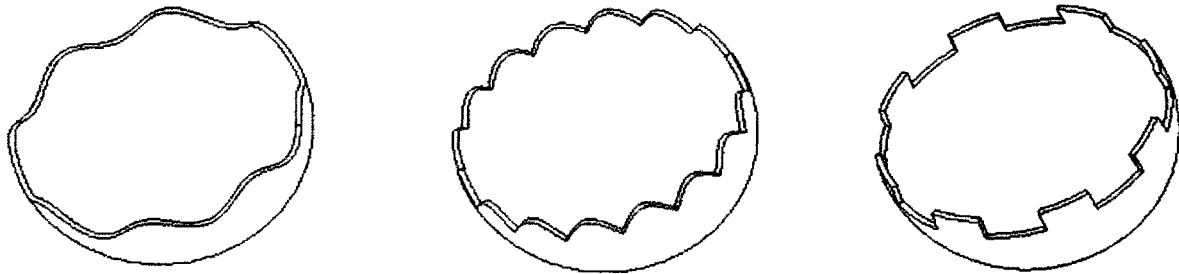

FIG. 24 Scalloped Edge Pattern

4.38.1 Toys must not contain a loose as-received hazardous magnet or a loose as-received hazardous magnetic component.

4.38.2 Toys shall not liberate a hazardous magnet or a hazardous magnetic component after being tested in accordance with 8.8 and 8.9 and magnet use and abuse testing as specified in 8.24.

4.38.3 Hobby, craft, and science kit-type items intended for children over 8 years of age, where the finished product is primarily of play value, that contain a loose as-received hazardous magnet or a loose as-received hazardous magnetic component, or both, are exempt from the requirements of 4.38.1 and 4.38.2 provided they comply with the requirements for safety labeling described in 5.17.

4.39 *Jaw Entrapment in Handles and Steering Wheels:*

4.39.1 These requirements are intended to address potential jaw entrapment in handles and steering wheels that are located such that they are accessible for teething in the following categories of toys intended for children under 18 months of age: activity tables intended to be played with by a standing child, large bulky toys, stationary floor toys, push toys intended to be pushed by a child walking upright, and ride-on toys.

4.39.2 Handles that are connected to the toy with a hinge and handles made from a pliable material (for example, straps and ropes) are exempt from this requirement.

4.39.3 Openings in handles and steering wheels that allow a 0.75 by 0.75 by 1 in. (1.9 by 1.9 cm by 2.5 cm) test fixture to pass completely through must also allow a 1.5 by 2.5 by 1 in. (3.8 by 6.35 by 2.5 cm) test fixture to pass completely through (see Fig. 25). Test fixtures can be made of any rigid material. The test fixture shall be oriented such that the 0.75-in. (1.9-cm) dimension and the 2.5-in. (6.35-cm) dimension is parallel with the major dimension of the handle or steering wheel opening.

5. Labeling Requirements

5.1 *Federal Government Requirements*—All toys that fall within the definitions and requirements of the U.S. FHSA shall conform to the labeling requirement of that act. For specific requirements, reference 16 CFR 1500.3, 1500.14, 1500.19, 1500.82, 1500.83, 1500.86, 1500.121, 1500.122, 1500.123, 1500.125, 1500.126, 1500.127, 1500.128, 1500.130, 1505.3, and 1511.7. In addition, state labeling requirements may exist.

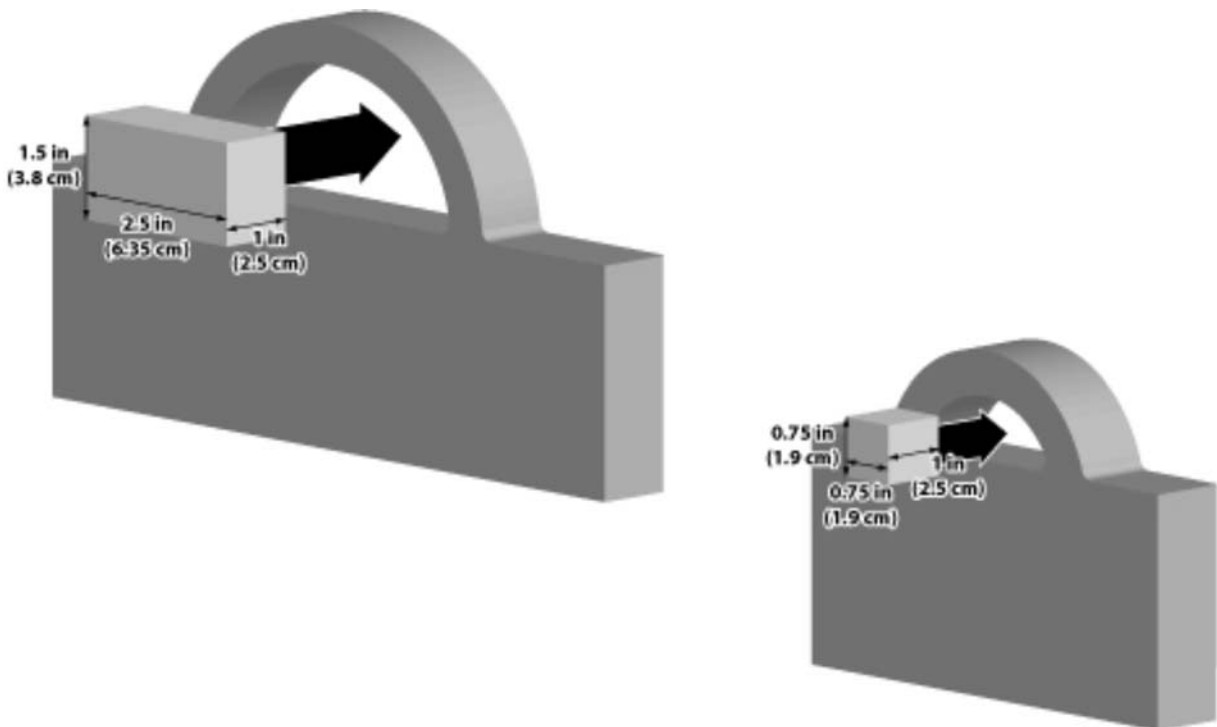

FIG. 25 Jaw Entrapment

5.2 *Age Grading Labeling*—Toys that are subject to any of the requirements of this specification should be labeled to indicate the minimum age for intended use or have such labeling on any retail packaging. If the toy or toy package is not age labeled in a clear and conspicuous manner or, based on such factors as marketing practices and the customary patterns of usage of the toy by children, is inappropriately age labeled, the toy shall be subjected to the most stringent applicable requirements within this specification. (Examples: (1) a tensile force of 15 lbf (67 N) shall be required instead of 10 lbf (45 N) when testing in accordance with 8.9 if no limiting age range is specified; (2) the “highest age of the age range” in 4.15 would be 14 years, the maximum age addressed in the scope of this specification.)

5.2.1 For certain toys, such as costumes and riding toys, it may also be appropriate to label the toy or its package, or both, in terms of height or weight limitations.

5.2.2 Guidelines for determining the appropriate age grade for toys are provided in Annex A1 of this specification.

5.3 *Safety Labeling Requirements*—Certain toys, and in some cases their packages, are required to carry safety labeling to comply with this specification.

5.3.1 Required safety labeling shall consist of an alert symbol (an exclamation mark within an equilateral triangle), a signal word (CAUTION or WARNING), and text that describes the hazard that is present. Additionally, safety labeling may contain text about what to do or not to do to avoid injury (for example, “Keep out of baby’s reach”). The signal word shall be in all upper case sans serif letters not less than 1/8 in. (3.2 mm) in height and shall be center or left aligned. The alert symbol shall directly precede the signal word. The height of the triangle shall be at least the same height as the signal word. The height of the exclamation point shall be at least half the height of the triangle and be centered vertically in the triangle. Text describing the hazard(s) and hazard avoidance behavior(s) shall appear in sans serif lettering and shall be either left aligned or center justified. Capital letters shall be no less than 1/16 in. (1.6 mm). Recognizing space constraints, it is recommended, that where possible, such text begin on the next line below the signal word, and that a new line be used for each subsequent statement or separate thought.

5.3.2 Sections 5.4, 5.5, 5.6, 5.7, 5.11, and 5.15 require the signal word WARNING. When no signal word is specified for safety labeling in accordance with 5.3, it is recommended that the signal word CAUTION be used to indicate a potentially hazardous situation which could result in minor or moderate injury, and that the signal word WARNING be used to indicate a potentially hazardous situation which could result in death or serious injury.

5.3.3 Sections 5.11 and 5.15 specify required text describing the hazard(s) and hazard avoidance behavior(s). When no required text is specified for safety labeling in accordance with 5.3, the text is left to the discretion of the manufacturer. Sections 5.4, 5.5, 5.6, 5.7, and 5.15.1.1 provide recommended text to describe the hazard(s) and hazard avoidance behavior(s).

5.3.4 The required safety labeling described throughout Section 5 shall be on the principal display panel.

5.3.5 For toy items packed as premiums in or on a package containing other items, safety labeling shall be on the toy package, and similar labeling shall appear on the larger package.

5.3.6 All safety labeling shall be conspicuous and legible, shall be separated distinctively from any other wording or designs, and shall appear in the English language at a minimum. Such labeling shall be clearly visible to the intended audience and shall be in a color contrasting with the background on which it appears.

5.3.7 When safety labeling is printed onto the toy itself using a decoration process such as hot stamping, silk screening, or a similar process, it shall remain legible after normal use and reasonably foreseeable abuse when tested in accordance with 8.5-8.10.

5.3.8 When safety labeling is affixed to a toy in the form of an applied label, the label shall be applied so that it adheres firmly to the toy and none of its edges is lifted off the surface of the toy. Such label shall remain legible after normal use and reasonably foreseeable abuse when tested in accordance with 8.5-8.10.

5.4 *Aquatic Toys*—Aquatic toys and their packages shall carry safety labeling in accordance with 5.3, consisting of the signal word “WARNING” and contain, at a minimum, the following text or equivalent text which clearly conveys the same warning: *This is not a lifesaving device. Do not leave child unattended while device is in use.* In addition, no advertising copy or graphics shall state or imply that the child will be safe with such a toy if left unsupervised.

5.5 *Crib and Playpen Toys*—This requirement is applicable to toys intended to be strung across a crib or playpen by means of string, cord, elastic, or straps (including, but not limited to, crib exercisers, crib gyms, and activity toys).

5.5.1 *Age Grading*—Crib and playpen toys, as well as their packages, shall be labeled with the following text or equivalent information (text or graphic), which clearly conveys the age grade: *from birth to 5 months.*

5.5.2 *Safety Labeling*—Crib and playpen toys shall carry safety labeling, in accordance with 5.3, consisting of the signal word “WARNING” and contain, at a minimum, the following text or equivalent text which clearly conveys the same warning: *Possible entanglement or strangulation. Remove toy when baby begins to push up on hands and knees.*

5.6 *Mobiles*—This section addresses all mobiles intended to be attached to a crib, playpen, wall, or ceiling.

5.6.1 *Age Grading*—Mobiles intended to be attached to a crib or playpen, as well as their packages, shall be labeled with the following text or equivalent information (text or graphic), which clearly conveys the age grade: *from birth to 5 months.*

5.6.2 *Safety Labeling:*

5.6.2.1 Mobiles intended to be attached to a crib or playpen, and mobiles intended to be attached to a crib or playpen and later moved to a wall or ceiling, as well as their packages, shall carry safety labeling in accordance with 5.3. The labeling shall consist of the signal word “WARNING” and contain, at a minimum, the following text or equivalent text which clearly conveys the same warning: *Possible entanglement injury. Keep*

out of baby’s reach. Remove mobile from crib or playpen when baby begins to push up on hands and knees.

5.6.2.2 Mobiles intended to be attached only to a wall or ceiling, as well as their packages, shall carry safety labeling in accordance with 5.3. The labeling shall consist of the signal word “WARNING” and contain, at a minimum, the following text or equivalent text which clearly conveys the same warning: *Possible entanglement injury. Keep toy out of baby’s reach.*

5.7 *Stroller and Carriage Toys*—Toys intended exclusively to be strung across strollers or carriages by means of string, cords, elastic, or straps shall carry safety labeling in accordance with 5.3. The labeling shall consist of the signal word “WARNING” and contain, at a minimum, the following text or equivalent text which clearly conveys the same warning: *Possible entanglement or strangulation injury when attached to crib or playpen. Do not attach to crib or playpen.*

5.8 *Toys Intended to be Assembled By an Adult*—Packages of toys that are intended to be assembled by an adult and that in their unassembled state contain potentially hazardous sharp edges or points, or small parts if the toy is intended for children under 3 years of age, shall carry safety labeling in accordance with 5.3 stating that the toy is to be assembled by an adult.

5.9 *Simulated Protective Devices*—Toys that simulate safety protective devices (examples include, but are not limited to, construction helmets and sports helmets), as well as their packages, shall carry safety labeling as defined in 5.3, stating that these toys are not safety protective devices.

5.10 *Toys with Functional Sharp Edges or Points*—Toys that are intended for use by children between the ages of 48 and 96 months, which contain accessible potentially hazardous sharp edges or sharp points that are a necessary part of the function of the toy, shall carry safety labeling on their packages as defined in 5.3, stating that a sharp edge or sharp point, or both, exists.

5.11 *Small Objects, Small Balls, Marbles, and Balloons:*

5.11.1 The packages of small balls, marbles, balloons, and certain toys and games, any descriptive material that accompanies them, and, if unpackaged and unlabeled, any retail display container provided by manufacturers or importers shall carry safety labeling in accordance with 16 CFR 1500.19(b).

5.11.1.1 In accordance with 16 CFR 1500.19(d), all labeling statements required by 5.11 shall appear at least in the English language on the principal display panel (except under 5.11.7) and shall be blocked together within a square or rectangular area, with or without a border. The label design, the use of vignettes, or the proximity of other labeling or lettering shall not obscure or render inconspicuous any labeling statement.

5.11.1.2 The statements required by 5.11 must appear on at least two lines and appear on a solid background and be separated from all other graphic material by a space no smaller than the minimum allowable height of the type size for “other cautionary material” (for example the phrase “Not for children under 3 yrs.”). If not separated by that distance, the labeling statements must be surrounded by a border line.

5.11.1.3 All labeling statements required by 5.11 shall comply with the following type size requirements based on the computed area of the principal display panel. For these

purposes, Signal Word means the word “Warning” and the words “Safety Warning”; Statement of Hazard means “Choking Hazard”; Other Material means all other remaining statements.

Area, in. ²	0–2	+2–5	+5–10	+10–15	+15–30	+30–100	+100–400	+400
Type Size—Signal Word	3/64 in.	1/16 in.	3/32 in.	7/64 in.	1/8 in.	5/32 in.	1/4 in.	1/2 in.
Type Size—Statement of Hazard	3/64 in.	3/64 in.	1/16 in.	3/32 in.	3/32 in.	7/64 in.	5/32 in.	1/4 in.
Type Size—Other Material	1/32 in.	3/64 in.	1/16 in.	1/16 in.	5/64 in.	3/32 in.	7/64 in.	5/32 in.

5.11.1.4 An equilateral triangle with an exclamation point (shown in 5.11.2) shall precede the signal word. The height of the triangle shall be equal to or exceed the height of the letters of the signal word “WARNING” and separated from it by a distance at least equal to the space occupied by the first letter of the signal word. The height of the exclamation point shall be at least half the height of the triangle, and be centered vertically in the triangle.

5.11.2 For toys and games intended for children at least 3 years old but less than 6 years of age, and which contain as-received small part(s), the labeling shall read:

△ WARNING:
CHOKING HAZARD—Small parts.
Not for children under 3 yrs.

5.11.3 For any small ball intended for children 3 years of age or older the labeling shall read:

△ WARNING:
CHOKING HAZARD—Toy contains a small ball.
Not for children under 3 yrs.

5.11.3.1 For any toy or game intended for children who are at least 3 years old but less than 8 years of age that contains a small ball the labeling shall read:

△ WARNING:
CHOKING HAZARD—Toy contains a small ball.
Not for children under 3 yrs.

5.11.4 For any marble intended for children 3 years of age or older the labeling shall read:

△ WARNING:
CHOKING HAZARD—This toy is a marble.
Not for children under 3 yrs.

5.11.4.1 For any toy or game intended for children who are at least 3 years of age but less than 8 years of age that contains a marble the labeling shall read:

△ WARNING:
CHOKING HAZARD—Toy contains a marble.
Not for children under 3 yrs.

5.11.5 For any latex balloon or any toy or game that contains a latex balloon, the labeling shall read:

△ WARNING:
CHOKING HAZARD—Children under 8 yrs. can choke or suffocate on uninflated or broken balloons.
Adult supervision required.

Keep uninflated balloons from children.
Discard broken balloons at once.

5.11.6 *Combination of Labeling Statements*—The labels of products that contain more than one item subject to the

requirements of 5.11 may combine information, if the condensed statement contains all of the information necessary to describe the potential hazard associated with each product. For products that contain a balloon *and* a small ball, small object, or marble, only the signal word and statement of hazard may be combined.

5.11.7 *Alternative Labeling Statements for Items Subject to the Requirements of 5.11*—Labeling statements on small packages of toys or balloons that have a principal display panel of 15 in.² or less and that display cautionary statements in three or more languages may appear on a display panel other than the principal display panel if the principal display panel bears the appropriate statement below and bears an arrow or other indicator pointing toward or directing the purchaser’s attention to the display panel on the package where the full labeling statement appears.

5.11.7.1 For a toy or game that is or contains a small object, small ball, or marble:

△ SAFETY WARNING

5.11.7.2 For a balloon or a toy or game that contains a balloon:

△ WARNING—Choking Hazard

5.12 *Toy Caps*—Refer to 16 CFR 1500.86 for required labeling.

5.13 *Art Materials*—Toys and components of toys that fall within the definition of art material as found in 16 CFR 1500.14 (b) (8) shall be labeled in accordance with the provisions of that section and Practice D4236.

5.14 *Electric Toys*—Refer to 16 CFR 1505.3 for required labeling.

5.15 *Battery-Operated Toys*—Toys with non-replaceable batteries that are accessible with the use of a coin, screwdriver, or other common household tool shall bear a statement that the battery is not replaceable. If the manufacturer determines that it is impractical to label the product, this information shall be placed on the packaging or in the instructions.

5.15.1 *Battery-Powered Ride-on Toys*:

5.15.1.1 Battery powered ride-on toys shall carry safety labeling in accordance with 5.3, consisting of the signal word “WARNING” and contain, at a minimum, text which clearly conveys the following:

(a) To reduce the risk of injury, adult supervision is required. Never use in roadways, near motor vehicles, on or near steep inclines or steps, swimming pools or other bodies of water; always wear shoes, and never allow more than ____ rider(s)

(b) RISK OF FIRE. Do not bypass. Replace only with _____. (Note: This warning must be placed at the location of any user replaceable fuse or circuit protection device. Manufacturer should state the part number or equivalent.

5.15.1.2 The packaging or point-of-sale literature of battery-powered ride-on toys shall state the manufacturer’s recommended user age or weight limitations for use of the toy, or both.

5.15.1.3 The packaging or point-of-sale literature of battery-powered ride-on toys shall bear the warnings as specified in 5.15.1.

5.16 *Promotional Materials*—Packaging, literature accompanying toys, and point-of-sale presentations shall not use words, statements, or graphics that are inconsistent in any way with the safety labeling instructions for use or assembly or age grading of the toy.

5.17 *Magnets*—The packaging and instructions of hobby and crafts items and science kit-type items for children over 8 years of age which contain a loose as-received hazardous magnet or a loose as-received hazardous magnetic component shall carry safety labeling in accordance with 5.3. The labeling shall consist of the signal word “WARNING” and contain, at a minimum, the following text or equivalent text which clearly conveys the same warning: “*This product contains (a) small magnet(s). Swallowed magnets can stick together across intestines causing serious infections and death. Seek immediate medical attention if magnet(s) are swallowed or inhaled.*”

6. Instructional Literature

6.1 *Definition and Description*—Information and instructions that are provided for the safe use or assembly, or both, of a toy, whether on the package or in leaflet form, shall be easy to read and understand by persons of the age level for whom the instructions and information are intended, including, if appropriate, children for whom the toy is intended. All such literature shall be shown in the English language at a minimum.

6.2 *Crib and Playpen Toys*—Toys intended to be strung across a crib or playpen by means of string, cords, elastic, or straps (including, but not limited to, crib exercisers, crib gyms, and activity toys) shall be provided with instructions for proper assembly, installation, and use to insure that the product does not present an entanglement or strangulation hazard. The instructions shall include at least the following information:

6.2.1 This toy is not intended to be “mouthed” by the baby and should be positioned clearly out of reach of the baby’s face and mouth.

6.2.2 On cribs with adjustable mattress levels, the highest position may allow the toy to be too close to the baby. The second or lower position is more appropriate.

6.2.3 The drop side of the crib should never be lowered with the toy in place and the baby left unattended.

6.2.4 Always attach all provided fasteners (strings, straps, clamps, etc.) tightly to a crib or playpen according to the instructions. Check frequently.

6.2.5 Do not add additional strings or straps to attach to a crib or playpen.

6.3 *Mobiles*—Mobiles intended to be mounted on a crib, playpen, or wall or ceiling nearby shall be provided with instructions for proper assembly, installation, and use to insure that the product does not present an entanglement hazard. The instructions shall include at least the following information:

6.3.1 A crib mobile is intended for visual stimulation and is not intended to be grasped by the child.

6.3.2 If attached to the crib or playpen, remove when baby begins to push up on hands and knees. If so designed, mount on wall or ceiling clearly out of a standing baby’s reach.

6.3.3 If mounted on a wall or ceiling, install the mobile clearly out of a standing baby’s reach.

6.3.4 Always attach all provided fasteners (strings, straps, clamps, etc.) tightly to a crib or playpen according to the instructions. Check frequently.

6.3.5 Do not add additional strings or straps to attach to a crib or playpen.

6.4 *Toys Intended to be Assembled By an Adult*—Assembly instructions that accompany toys that are intended to be assembled by an adult and that in their unassembled state contain potentially hazardous sharp edges or sharp points, or small parts if the toy is intended for children under 3 years of age, shall carry safety labeling as defined in 5.3 and also state that the toy is to be assembled by an adult.

6.5 *Battery-Operated Toys*—For toys that use more than one battery in one circuit, the instructions or the toy shall be marked with the following (or equivalent) information.

6.5.1 Do not mix old and new batteries.

6.5.2 Do not mix alkaline, standard (carbon-zinc), or rechargeable (nickel-cadmium) batteries.

6.5.3 Instructions supplied with battery-powered ride-on toys shall contain guidance for safe use and maintenance of the toy. The instructions shall include at least the following:

6.5.3.1 Maximum weight or age limitations, or both, for safe use of the toy,

6.5.3.2 The kinds of surfaces which are appropriate for safe use of the toy,

6.5.3.3 The warning statements contained in 5.15.1.1,

6.5.3.4 Only use the battery(ies) specified by the manufacturer, and

6.5.3.5 Only use the charger(s) specified by the manufacturer.

6.6 *Toys in Contact with Food*—The packages or instructions, or both, for toys and their components intended to be used in contact with food shall be labeled to alert caregivers to wash the product thoroughly before use.

7. Producer’s Markings

7.1 Either a principal component of a toy or the package of a toy shall be marked with the name and address of the producer or the distributor. In the case of toys sold in bulk, such as jacks or marbles, only the container need be marked. All of these markings shall be legible and so positioned as to be seen easily by the customer and shall resist normal use conditions. Toys may carry a code that will enable the producer to identify model changes except for toys comprising many loose components, in which case the container may be so coded.

7.2 *Battery-Powered Ride-on Toys*—Battery-powered ride-on toys shall bear a permanent label or marking identifying the manufacturer or distributor, place of business, the

model numbers, and a date of manufacture or date code that will allow determination of, at a minimum, the month and year of manufacture.

8. Test Methods

8.1 *General*—The inspection and test procedures contained herein are to be used to determine the conformance of products to the requirements of this specification. All types of toys covered by this specification must undergo the normal use and abuse tests in accordance with 8.5-8.10. The remaining tests in this section apply to types of toys as specified within the requirements of Section 4. The relevant tests for a type of toy can be performed in any order except where specified. Each test may be conducted on a different toy unless otherwise specified. The tests can be considered as qualification tests and not necessarily as quality control tests. These tests shall also be conducted when there is a design or material change in the toy. Each producer or distributor who represents his products as conforming to this specification may use statistically based sampling plans that are appropriate, but he shall keep such essential records as are necessary to document with a high degree of assurance his claim that all of the requirements of this specification have been met. Any test methods that are made mandatory by the CPSC shall supersede any applicable test methods in this section.

8.2 *Testing for Hazardous Substance Content*—The applicable sections of 16 CFR, issued under the FHSA to be used for determining the presence of hazardous substances, are given in Table 4. The references in Table 4 refer to the regulations issued on Sept. 27, 1973.

NOTE 6—The latest issue of the regulation shall be used to determine compliance of the toy with the requirements of this specification. The requirements of the FHSA are mandatory by law.

8.3 *Test Methods for Determination of Heavy Element Content in Toys, Toy Components and Materials:*

8.3.1 *Total Element Content Screening:*

8.3.1.1 Toy material under test is to be digested per the appropriate CPSC Method:

- (1) CPSC-CH-E1001-08.1 (metal substrates)
- (2) CPSC-CH-E1002-08.1 (non-metal substrates)
- (3) CPSC-CH-E1003-09 (paint and similar surface-coating materials)

8.3.1.2 With the following modification: Concentrated HNO₃ digestant is to be replaced with aqua regia (three parts concentrated HCl to one part concentrated HNO₃). Glass and ceramic components shall be digested using three parts HF to one part HNO₃. Certain polymeric materials such as PVC and CPVC may require use of three parts concentrated HNO₃ to

TABLE 4 Determination of Hazardous Substance Content

Hazardous Substance	Regulation (Title 16 CFR)
Toxic substance	1500.3(b)5, 1500.3(c)2, and 1500.40
Corrosive substance	1500.3(b)7, 1500.3(c)3, and 1500.41
Irritant substance	1500.3(b)8, 1500.3(c)4, 1500.41, and 1500.42
Strong sensitizer	1500.3(b)9, 1500.3(c)5, and 1500.13
Pressure-generating substance	1500.3(c)7
Radioactive substance	1500.3(b)11 and 1500.3(c)8
Flammability	1500.3(b)10, 1500.3(c)6, 1500.43, and 1610.

one part 30 % H₂O₂ for complete digestion; in all cases, knowledge-based adjustments to the above digestant mixtures on a case-by-case basis may be necessary for products made from certain materials, and are allowable so long as complete digestion is achieved and avoidance of formation of insoluble metal salts is taken into consideration. In all cases, the use of concentrated H₂SO₄ is to be avoided to reduce the possibility of the formation of insoluble metal sulfates.

8.3.1.3 Resulting digested material is to be filtered and diluted as prescribed, then analyzed by atomic spectroscopy or other appropriate validated method for total content of all eight elements listed in [Table 1](#) and [Table 2](#); if results are below soluble limits for each element as prescribed in the appropriate table, the material can be considered to conform to requirements of [4.3.5](#) or [4.3.5.2](#), or both, without further testing. If soluble limits in the appropriate table are exceeded, additional testing per [8.3.2](#) (for paint and similar surface-coating materials) or [8.3.5](#) (substrate materials) will be required to confirm compliance. In addition, if the toy or toy component is a metallic small part, it is to be tested per [8.3.5.5\(3\)](#). Composite samples of up to three like materials (for example, three colors of polystyrene plastic) are acceptable (if performed in accordance with [Annex A7](#)) for total element screening, but not for soluble element testing if such is required.

NOTE 7—With the exception of required total lead content testing (see [4.3.5.1](#)), it may be elected to omit total element screening and perform only soluble element testing per [8.3.2-8.3.6](#).

8.3.2 *Method to Dissolve Soluble Matter for Surface Coatings*—Soluble elements are extracted from toys under conditions that simulate the situation in which the materials stay 4 h in the alimentary tract after swallowing. The content of soluble elements in the extract is determined.

8.3.2.1 *Apparatus*—Normal laboratory apparatus and the following:

(1) *Metal Sieve*, plain weave wire mesh stainless steel metal sieve with a nominal opening of 0.5 mm and the following specifications: (a) Nominal wire diameter: 0.315 μm; (b) Maximum size deviation for an individual opening: ±0.090 μm; (c) Tolerance for average opening: ±0.018 mm; and (d) 6 % or fewer of the openings to exceed the nominal plus 0.054 mm.

(2) *pH*, a means of measuring pH with a minimum accuracy of 0.2 pH units.

(3) *Membrane Filter*, with a pore size of 0.45 μm.

(4) *Centrifuge*, capable of centrifuging at 5000 ± 500 × g RCF ($g = 9.80665 \text{ m/s}^2$)

(5) A means to constantly agitate the mixture at a temperature of 37 ± 2°C.

(6) Container, of gross volume between 1.6 and 5.0 times that of the volume of HCL extractant.

8.3.2.2 *Reagents*—Use only reagents of recognized analytical grade during the analysis.

(1) Hydrochloric acid (HCl) solution; concentration = (0.07 ± 0.005) mol/l.

(2) Hydrochloric acid (HCl) solution; concentration = (0.14 ± 0.010) mol/l.

(3) Hydrochloric acid (HCl) solution; concentration = approximately 1 mol/l.

(4) Hydrochloric acid (HCl) solution; concentration = 2 mol/l.

(5) Hydrochloric acid (HCl) solution; concentration = approximately 6 mol/l.

(6) n-heptane, (C₇H₁₆); 99 %.

(7) Water, of at least grade 3 purity in accordance with Specification [D1193](#) or [ISO 3696](#).

8.3.3 *Preparation of Test Samples*—A laboratory sample for testing shall consist of a toy in the form in which it is marketed, excluding the package and packaging components.

8.3.3.1 The test sample shall be taken from the accessible portions of a single toy sample.

8.3.3.2 Identical materials in the sample may be combined and treated as a single sample. A single sample may not consist of more than one material or color (that is, composite testing is not allowed).

8.3.3.3 The test sample can alternatively be taken from materials in a form such that they are representative of the relevant material specified above.

8.3.3.4 When a toy is intended to be taken apart or can be taken apart without the use of tools, each piece shall be considered separately.

8.3.3.5 For reference purposes, the sample may be taken from the raw material rather than scraped from the sample.

8.3.3.6 Scrape the coating off the test sample, and grind it through the sieve. Obtain a portion of not less than 100 mg of the resulting material.

(1) Where there is only between 10 and 100 mg of uniformly ground material available, test that quantity and calculate the results as if 100 mg of the sample had been available. The report should note this procedure and the actual sample amount.

(2) If there is less than 10 mg of sample available, the test is not performed.

(3) In the case of coatings that by their nature cannot be ground (for example, elastic, rubber, or plastic paint), test the sample as it was removed from the toy.

NOTE 8—The methods and exclusions given in [8.3.3.1](#) do not apply to surface coatings being tested for total lead content as required by [16 CFR 1303](#). Total lead determination under CPSC requirements at [16 CFR 1303](#) applies to any coating that can be scraped off, regardless of the amount, with results calculated based on the actual sample weight.

8.3.4 *Test Procedures*:

8.3.4.1 Prepare a test portion in accordance with [8.3.3](#).

8.3.4.2 Mix the test portion so prepared with 50 times its mass of an aqueous solution of 0.07 mol/L hydrochloric acid at 37 ± 2°C. In the case of a test portion of less than 100 mg, mix the test portion with 5.0 mL of this solution at the given temperature. Shake for 1 min.

(1) Check the acidity of the mixture. If the pH is greater than 1.5, add dropwise while shaking an aqueous solution of 2 mol/L (7.3 % m/m) hydrochloric acid until the pH is between 1.0 and 1.5. Protect the mixture from light. Shake the mixture efficiently for 1 h continuously, and then allow the mixture to stand for 1 h at 37 ± 2°C.

(2) Without delay, separate the solids from the mixture by filtration through a membrane filter with a pore size of 0.45 μm. If necessary, centrifuge at 5000 g for no longer than 10 min.

Analyze the solution by atomic spectroscopy or other appropriate validated method to determine the concentration of the elements identified in 4.3.5.1. If it is not possible to examine the sample within one working day, stabilize by the addition of hydrochloric acid so that the resulting solution HCl concentration is approximately 1 mol/L.

NOTE 9—It has been shown that the extraction of soluble cadmium can reveal a two-fold to five-fold increase when extraction is conducted in the light rather than the dark.

8.3.4.3 The analytical results as determined in 8.3.4.2 shall be adjusted by subtracting the analytical correction factor in the following table using the following method. This is necessary to make statistical correction for interlaboratory error.

Element	Analytical Correction							
	Sb	As	Ba	Cd	Cr	Pb	Hg	Se
Analytical correction, %	60	60	30	30	30	30	50	60

(1) *Example of Calculations Using the Table:*

Example 1—The analytical result for lead is 120 mg/kg; the correction factor from the table is 30 % (0.30).

Adjusted analytical results = $120 - (120 \times 0.30) = 120 - 36 = 84$ mg/kg.

The result does not exceed the allowed value for lead in the table and is therefore acceptable.

Example 2—The analytical result for chromium is 90 ug/kg; the correction factor from the table is 30 % (0.30).

Adjusted analytical results = $90 - (90 \times 0.30) = 90 - 27 = 63$ mg/kg.

The result exceeds the allowed value for chromium in the table and is therefore not acceptable.

8.3.5 *Soluble Element Test Method for Substrate Materials*—Soluble elements are extracted from toy materials under conditions which simulate the material remaining in contact with stomach acid for a period of time after swallowing. The concentrations of the soluble elements are determined quantitatively.

NOTE 10—Optional, alternate test methods are permitted, as described in 8.3.6.

8.3.5.1 *Apparatus*—As described in 8.3.2.1.

8.3.5.2 *Reagents*—As described in 8.3.2.2.

8.3.5.3 *Selection of Test Portions:*

(1) A laboratory sample for testing shall consist of a toy either in the form in which it is marketed, or in the form in which it is intended to be marketed. Test portions shall be taken from accessible parts of a single toy sample, that is, identical materials in the toy may be combined and treated as a single test portion but additional toy samples shall not be used. Test portions are only permitted to be composed of more than one material or color where physical separation (for example, dot printing), patterned textiles or mass limitation reasons, precludes the formation of discrete specimens.

(2) Test portions where less than 10 mg of material available are not tested.

NOTE 11—The requirement does not preclude that test portions can be taken from materials in a form such that they are representative of the relevant material specified above and the substrate upon which they are deposited.

8.3.5.4 Polymeric and similar materials including laminates, whether reinforced textile or not, but excluding other textiles.

(1) *Sample Removal/Preparation Procedure:*

(a) Obtain a test portion of not less than 100 mg of the polymeric or similar materials, avoiding heating of the materials, according to the following directions.

(b) Cut out test portions from the areas having the thinnest material cross section in order to ensure a surface area of the test pieces as large as possible in proportion to their mass. Each test piece shall in the uncompressed condition have no dimension greater than 6 mm.

(c) If the laboratory sample is not uniform in its material, a test portion shall be obtained from each different material present in a mass greater than 10 mg. In the case where there is between 10 and 100 mg of uniform material the mass of the test portion shall be reported in the test report and the quantity of the appropriate elements shall be calculated and reported as if 100 mg of the test portion had been used.

(2) *Test Procedure*—As described in 8.3.4.2 and 8.3.4.3.

8.3.5.5 *Glass/Ceramic/Metallic Materials:*

(1) *Sample Removal/Preparation Procedure*—Toys and components shall be first subjected to the relevant tests in accordance with Section 8. If any accessible glass, ceramic or metallic materials of the toy fits entirely within the small parts cylinder (see Fig. 3) before or after use and abuse testing, it shall be tested in accordance with 8.3.5.5(2) after removal of any coating in accordance with CPSC method CPSC-CH-E1003-09; metallic materials are also to be tested in accordance with 8.3.5.5(3) after removal of any coating in accordance with CPSC method CPSC-CH-E1003-09.

NOTE 12—Toys and components that have no accessible glass, ceramic or metallic materials are not tested according to 8.3.5.5. If a toy or component that is subject to testing per 8.3.5.5 consists of a combination of metallic and non-metallic materials (for example, a steel nut with a nylon locking insert), the non-metallic material is to be mechanically separated from the metallic material prior to the test, and only the metallic component is subjected to testing per 8.3.5.5; the non-metallic component is to be tested per the section of this standard applicable to the material type.

(2) *Test Procedure – Standard Soluble Elements:*

(a) Place the toy or component in a 50 mL glass container with nominal dimensions: height 60 mm, diameter 40 mm. Add a sufficient volume of an aqueous solution of 0.07 M HCl at $37 \pm 2^\circ\text{C}$ to just cover the toy or component. Cover the container, protect the contents from light and allow the contents to stand for 2 h at $37 \pm 2^\circ\text{C}$.

NOTE 13—This type of container will accommodate all components/toys that fit inside the small parts cylinder.

(b) Without delay, efficiently separate the solids from the solution, firstly by decantation followed by filtration using a membrane filter, and if necessary, by centrifuging at up to 5000 g.

(c) Separation shall be completed as soon as possible after the completion of the standing time; centrifuging shall take no longer than 10 min and shall be reported in the test report. If the resulting solutions are to be kept for more than 24 h prior to analysis they shall be stabilized by addition of hydrochloric

acid so that the HCl concentration of the stored solution is approximately 1.0 M.

(d) Analyze the solution for element content using atomic spectroscopy or other validated test methods.

(3) *Test Procedure—Special Soluble Cadmium (apply to metallic small parts only):*

(a) Metal toys and toy components which, either before or after use-and-abuse testing per Section 8, fit entirely within the small parts cylinder (see Fig. 3) shall be tested per CPSC test method CPSC-CH-E1004-11. At the conclusion of the prescribed 24-h extraction test, efficiently separate, without delay, the solids from the solution, firstly by decantation followed by filtration using a membrane filter, and if necessary, by centrifuging at up to 5000 g. Separation shall be completed as soon as possible after the completion of the extraction time; centrifuging shall take no longer than 10 min and shall be reported in the test report. If the resulting solutions are to be kept for more than 24 h prior to analysis they shall be stabilized by addition of hydrochloric acid so that the HCl concentration of the stored solution is approximately 1.0 M. Stored solutions shall be protected from light to the extent practicable.

(b) Analyze the solution for cadmium content using atomic spectroscopy or other validated test methods.

8.3.5.6 Other Materials, Whether Mass Colored or Not:

(1) *Sample Removal/Preparation Procedures:*

(a) Obtain a test portion of not less than 100 mg of the material according to 8.3.5.3 or 8.3.5.4, whichever is more appropriate.

(b) If the laboratory sample is not uniform in its material, a test portion shall be obtained from each different material present in a mass greater than 10 mg. Where there is between 10 and 100 mg of uniform material, the mass of the test portion shall be reported in the test report, and the quantity of the appropriate elements shall be calculated and reported as if 100 mg of the test portion had been used.

(c) If the material to be tested is coated with paint, varnish, lacquer, printing ink or similar material, remove this material per in accordance with CPSC method CPSC-CH-E1003-09 prior to testing per 8.3.5.6(2).

(2) *Test Procedures*—The materials shall be tested by the most appropriate method under 8.3. The method used shall be reported in the test report.

8.3.5.7 Materials Intended to Leave a Trace:

(1) *Sample Removal/Preparation Procedure for Materials in Solid Form:*

(a) Obtain a test portion of not less than 100 mg of the material by cutting into test pieces, which in the uncompressed condition shall have no dimensions greater than 6 mm.

(b) A test portion shall be obtained from each different material intended to leave a trace, present in the laboratory sample in a mass greater than 10 mg. Where there is between 10 and 100 mg of material, the mass of the test portion shall be reported in the test report and the quantity of the appropriate elements shall be calculated and reported as if 100 mg of the test portion had been used. If the material contains any grease, oil, wax or similar material, the test portion shall be enclosed in hardened filter-paper and these ingredients shall be removed with n-heptane using solvent extraction.

(2) *Sample Removal/Preparation Procedure for Materials in Liquid Form:*

(a) Obtain a test portion of not less than 100 mg of the material from the laboratory sample. The use of an appropriate solvent to facilitate the obtaining of a test portion is permitted.

(b) A test portion shall be obtained from each different material intended to leave a trace, present in the laboratory sample in a mass greater than 10 mg. Where there is between 10 and 100 mg of material, the mass of the test portion shall be reported in the test report and the quantity of the appropriate elements shall be calculated and reported as if 100 mg of the test portion had been used. If the material is intended to solidify in normal use and contains grease, oil, wax or similar material, the test portion shall be allowed to solidify under normal use conditions and the resulting material shall be enclosed in hardened filter-paper and the grease, oil, wax or similar material shall be removed with n-heptane by using solvent extraction.

(3) *Test Procedure for Samples not Containing Grease, Oil, Wax or Similar Material:*

(a) Using the appropriately sized container, mix the test portion so prepared with 50 times its mass of an aqueous solution at $37 \pm 2^\circ\text{C}$ of 0.07 M HCl (see 8.3.2.2). For a test portion mass of between 10 and 100 mg, mix the test portion with 5.0 mL of this solution at $37 \pm 2^\circ\text{C}$. Shake for 1 min. Check the acidity of the mixture.

(b) If the pH of the resulting solution is greater than 1.5, adjust the pH to between 1.0 and 1.5. If the pH is 2.5 or less, add dropwise, while shaking the mixture, 2 M HCl until the pH is between 1.0 and 1.5; if the pH is greater than 2.5, add dropwise, while shaking the mixture, 6M HCl until the pH is between 2.50 and 1.5, then add dropwise, while shaking the mixture, 2 M HCl until the pH is between 1.0 and 1.5. The amount of hydrochloric acid used in relation to the amount of solution shall be reported in the test report.

(c) Protect the mixture from light. Agitate the mixture at $37 \pm 2^\circ\text{C}$ (see 8.3.4.2) for 1 h continuously and then allow to stand for 1 h at $37 \pm 2^\circ\text{C}$.

(d) Without delay, efficiently separate the solids from the solution, firstly by filtration using a membrane filter and, if necessary, by centrifuging at up to 5000 g. Separation shall be completed as soon as possible after the completion of the standing time; centrifuging shall take no longer than 10 min and shall be noted in the test report.

(e) If the resulting solutions are to be kept for more than the working day prior to analysis they shall be stabilized by addition of hydrochloric acid so that the concentration of the stored solution is approximately 1.0M HCl.

(f) Analyze the solution for element content using atomic spectroscopy or other validated test methods.

(4) *Test Procedure for Samples Containing Grease, Oil, Wax or Similar Material:*

(a) With the test portion remaining in the hardened filter-paper, macerate the test portion so prepared with 25 times the mass of the original material with water at $37 \pm 2^\circ\text{C}$ so that the resulting mixture is homogeneous. Quantitatively transfer the mixture to the appropriate sized container. Add to the mixture an aqueous solution of 0.14 M HCl at $37 \pm 2^\circ\text{C}$ in the

proportion of 25 times the mass of the original test portion. In the case of a test portion mass between 10 and 100 mg macerate the test portion with 2.5 mL of water. Quantitatively transfer the mixture to the appropriate sized container. Add 2.5 ml of 0.14 M HCl at $37 \pm 2^\circ\text{C}$ to the mixture. Shake for 1 min.

(b) Check the acidity of the mixture. The amount of hydrochloric acid used in relation to the amount of solution shall be reported in the test report. Protect the mixture from light. Agitate the mixture at $37 \pm 2^\circ\text{C}$ for 1 h continuously and then allow to stand for 1 h at $37 \pm 2^\circ\text{C}$.

NOTE 14—The volume of the solution 0.07 M HCl or 0.14 M HCl, as the case may be, is calculated based on the mass of the test portion prior to de-waxing.

(c) Without delay, efficiently separate the solids from the solution, firstly by filtration using a membrane filter and, if necessary, by centrifuging at up to 5000 g. Separation shall be completed as soon as possible after the completion of the standing time; centrifuging shall take no longer than 10 min and shall be noted in the test report.

(d) If the resulting solutions are to be kept for more than the working day prior to analysis they shall be stabilized by addition of hydrochloric acid so that the concentration of the stored solution is approximately 1.0 M HCl.

(e) Analyze the solution for element content using atomic spectroscopy or other validated test methods.

8.3.6 Alternative Methods—For purposes of determining compliance with the requirements contained in 4.3.5, “reasonable and representative tests” shall be used. Reasonable and representative tests could be either the tests contained in 8.3.1, 8.3.2, or 8.3.3, or alternate tests which utilize apparatus or procedures, or both, other than those in 8.3. The following paragraphs set forth the conditions under which alternate tests with apparatus or procedures other than those described in 8.3, inclusive, will be considered reasonable and representative.

8.3.6.1 Persons and firms determining the compliance of materials subject to the requirements contained in 4.3.5 may base those determinations on any alternate test utilizing apparatus or procedures other than those in 8.3, inclusive, if such alternate test is as stringent as, or more stringent than, the tests in 8.3, inclusive. An alternate test is considered to be “as stringent as, or more stringent than” a test in 8.3 if, when testing identical specimens, the alternate test yields failing results as often as, or more often than, the test in 8.3, inclusive. Any person using such an alternate test must have data or information to demonstrate that the alternate test is as stringent as, or more stringent than, the test in 8.3, inclusive. For example XRF screening in accordance with Test Method F2853 protocol could be used if determined to be a more stringent test method to the extent applicable for the material tested.

8.3.6.2 The data or information required by paragraph 8.3.6.1 to demonstrate equivalent or greater stringency of any alternate test using apparatus or procedures other than those in 8.3, inclusive, must be in the possession of the person or firm desiring to use such alternate test before the alternate test may be used to support a determination of compliance against the requirements contained in 4.3.5.

8.3.6.3 The data or information required by paragraph 8.3.6.1 to demonstrate equivalent or greater stringency of any alternate test using apparatus or procedures other than those in 8.3, inclusive, must be retained for as long as that alternate test is used to support determinations of compliance against the requirements contained in 4.3.5, and for one year thereafter.

(1) Alternate method acceptability requires rigorous statistical analysis of limits of acceptability to show consistency of results of alternate methods to prescribed method results. This analysis must be performed separately for each substrate type and heavy element (for example, results for cadmium in metal may not be automatically assumed to apply to barium in plastic, etc.). Alternate methods, once validated, should be submitted to ASTM for inclusion in the standard to avoid inconsistency of results.

8.4 Tests for Cleanliness and Preservative Effectiveness:

8.4.1 Cleanliness of Materials—The cleanliness of cosmetics, liquids, pastes, putties, gels, and powders used in toys (excluding art materials) shall be determined using the methods in USP 24 <61> Microbial Limits Tests or the most current edition of the U.S. Pharmacopeia.¹⁵ Another method may be substituted provided it has been properly validated as giving equivalent or better results, as specified in USP 24 <61> or the most current edition of the U.S. Pharmacopeia. In conjunction with the chosen test method, the limits for determining the cleanliness of materials will consist of the most current guidelines for cosmetics set forth by the Cosmetic, Toiletry, and Fragrance Association (CTFA).

8.4.2 Preservative Effectiveness—The formulations of cosmetics used in toys shall be evaluated for the potential microbiological degradation, or they shall be tested for microbial control and preservative effectiveness using the methods and limits in USP 24 <51> Antimicrobial Effectiveness Testing or the most current edition of the U.S. Pharmacopeia.

8.5 Normal Use Testing—These tests are intended to simulate normal use conditions so as to ensure that hazards are not generated through normal wear and deterioration. The object of these tests shall be to simulate the normal play mode of the toy, and the tests are therefore unrelated to the reasonably foreseeable abuse tests of 8.6-8.13. The tests are intended to uncover hazards rather than to demonstrate the reliability of the toy. The fact that a mechanism or material of a toy fails during testing is relevant only if the failure creates a potential hazard. Toys shall be subject to appropriate tests to simulate the expected mode of use of the particular toy. For example, levers, wheels, catches, triggers, strings, wires, chains, and so on, that are intended to be actuated by a child shall be operated repeatedly. Spring or power-operated devices shall be tested similarly. The tests shall be conducted in an expected use environment. For example, toys intended for use in the bathtub shall be tested in soapy water, and toys intended for use in the sandbox shall be exposed to sand during testing. It is recognized that no specific

¹⁵ *Reagent Chemicals, American Chemical Society Specifications*, American Chemical Society, Washington, DC. For Suggestions on the testing of reagents not listed by the American Chemical Society, see *Analar Standards for Laboratory Chemicals*, BDH Ltd., Poole, Dorset, U.K., and the *United States Pharmacopeia and National Formulary*, U.S. Pharmacopeial Convention, Inc. (USPC), Rockville, MD.

requirements are defined here; it would not be possible in view of the wide range of toys covered by this specification. However, the manufacturer or distributor must do enough testing to satisfy himself that normal use during the estimated lifetime of the toy is being simulated. The toy shall be inspected after such tests, and hazards such as points, sharp edges, and release of small parts shall be evaluated in accordance with the relevant requirements listed in Section 4.

8.5.1 *Washable Toys*—Toys described as machine washable on the toy, package, or instructions shall be subjected to six machine washing and tumble drying cycles, as described in 8.5.1.1, unless a different drying method is specified by the toy manufacturer by means of a permanent label. They shall then be inspected for compliance with this specification.

8.5.1.1 *Conditions for Machine Washing and Tumble Drying*—Any commercially available top-loading washer, dryer, or laundry detergent intended for use in the home may be used for this test. The weight of each toy is determined prior to the beginning of the test. The toys, plus a dummy load of clothes sufficient to bring the total dry weight to a minimum 4 lb (1.8 kg), are washed in an automatic washing machine using the warm water setting and a 12-min wash cycle at the normal setting. The toys and dummy load shall then be tumble dried in an automatic clothes dryer using the warm setting, or air dried, until the load is dried. The toy shall be deemed dry when the final weight does not exceed the original dry weight by more than 10 %.

8.6 *Abuse Testing*—The tests described in 8.7-8.13 are to simulate the exposure of a toy to mechanical damage through dropping, throwing, and other actions likely to be performed by a child, which are characterized as reasonably foreseeable abuse. After testing, the toy shall be examined for mechanical hazards, such as hazardous sharp edges and points, and ingestion hazards, such as small liberated components, chips, or fragments. The severity of the abuse tests described in 8.7, 8.8, 8.9, 8.10, and 8.12 shall be determined according to the age group for which the toy is intended. If the toy is intended for an age group that spans more than one age group according to Table 5, the toy shall be subjected to the most severe test. Unless otherwise specified, none of the abuse testing described in 8.7-8.12 applies to toys intended for children over 96 months

of age. Toys reasonably intended to be assembled by an adult, and not intended to be taken apart by a child, shall be tested only in the assembled state if the shelf package and assembly instructions indicate prominently that the article is to be assembled by an adult. Individual parts of toys that are intended to be assembled by children shall be tested as well as the fully assembled toy; however, the assembled toy shall be made of components that have not been subjected to the abuse testing.

8.7 *Impact Tests*—These tests are intended to simulate situations in which possible damage can occur to a toy by reason of its falling from a crib, table, or counter top, or other impact situations that may occur as a result of reasonably foreseeable abuse. After undergoing the appropriate test, the toy shall be examined for possible hazards, such as points, edges, or ingestible objects, in accordance with the relevant requirement of Section 4.

8.7.1 *Drop Test*—Except for toys covered in 8.7.2, toys falling below the weight limit given below shall be dropped onto a specified impact area. The number of times the toy will be dropped, and the height from which it is dropped, is to be determined from Table 5. The toy shall be dropped in random orientation. The test sample shall be allowed to come to rest after each drop and shall be examined and evaluated before continuing. The impact medium shall consist of a 1/8-in. (3-mm) nominal thickness of Type IV vinyl composition tile, composition 1-asbestos free, as specified in Federal Specification SS-T-312B over at least a 2.5-in. (64-mm) thickness of concrete. The impact area shall be at least 3 ft² (0.3 m²). The recommended batteries shall be in place during the drop test for battery-operated toys. If no specific type of battery is recommended, the heaviest battery that is generally available shall be used.

Age Group	Weight Criteria, lb (kg)
18 months or less	less than 3 ± 0.01 (1.4)
over 18 months, not over 36 months	less than 4 ± 0.01 (1.8)
over 36 months, not over 96 months	less than 10 ± 0.01 (4.5)

8.7.2 *Tipover Test for Large, Bulky Toys*—Large, bulky toys shall not be subjected to the drop test of 8.7.1, but they shall be tipped over according to the following procedure:

TABLE 5 Test Parameters for Use and Abuse Tests

Test	Age Category of Intended User, months	Numerical Value	
		Stated by the Voluntary Standard	Recommended for Toy Manufacturers
Drop test	0 to 18	10 × 4.5 ft ± 0.5 in. (137 cm)	4 ft, 6.5 in. (1.38 m)
	over 18 to 36	4 × 3.0 ft ± 0.5 in. (91 cm)	3 ft, 0.5 in. (0.93 m)
	over 36 to 96	4 × 3.0 ft ± 0.5 in. (91 cm)	3 ft, 0.5 in. (0.93 m)
Torque test	0 to 18	2 ± 0.2 in.-lbf (0.23 N-m)	2.2 in.-lbf (0.25 N-m)
	over 18 to 36	3 ± 0.2 in.-lbf (0.34 N-m)	3.2 in.-lbf (0.36 N-m)
	over 36 to 96	4 ± 0.2 in.-lbf (0.45 N-m)	4.2 in.-lbf (0.47 N-m)
Tension test	0 to 18	10 ± 0.5 lbf (44.5 N)	10.5 lbf (46.7 N)
	over 18 to 36	15 ± 0.5 lbf (66.8 N)	15.5 lbf (69.0 N)
	over 36 to 96	15 ± 0.5 lbf (66.8 N)	15.5 lbf (69.0 N)
Compression test	0 to 18	20 ± 0.5 lbf (89.0 N)	20.5 lbf (91.2 N)
	over 18 to 36	25 ± 0.5 lbf (111.3 N)	25.5 lbf (113.5 N)
	over 36 to 96	30 ± 0.5 lbf (133.5 N)	30.5 lbf (135.7 N)
Flexure test	0 to 18	10 ± 0.5 lbf (44.5 N)	10.5 lbf (46.7 N)
	over 18 to 36	15 ± 0.5 lbf (66.8 N)	15.5 lbf (69.0 N)
	over 36 to 96	15 ± 0.5 lbf (66.8 N)	15.5 lbf (69.0 N)

8.7.2.1 *Tipover Test for Large, Bulky Toys*—Large, bulky toys shall be tested for impact by tipping over three times, one of which is in the worst attitude by pushing the sample slowly past its center of balance onto the impact medium described in 8.7.1.

8.7.3 *Tumble Test for Wheeled Toys*—Wheeled toys weighing more than 3 lb (1.4 kg) but not more than 10 lb (4.5 kg) shall be tumbled down a flight of six steps with risers not less than 7 in. (180 mm) high (see Fig. 26). The treads may be wood, cement, or metal. The toy, including accessories, where applicable, shall be caused to fall down the steps two times in each of four attitudes: tumbling forwardly end-over-end and tumbling rearwardly end-over-end from each side. The toy shall be pushed slowly over the edge of the top step in the appropriate attitude and released as soon as it begins to fall of its own weight. The test shall be considered complete for an attitude even if the toy does not reach the bottom of the flight of steps.

8.7.4 *Impact Test for Toys that Cover the Face*—The toy shall be held firmly in a suitable clamp with that portion that covers or surrounds the eyes (in the case of cutout eye holes) in a horizontal plane. Drop a 5/8-in. (16-mm) diameter steel ball weighing 0.56 oz. (15.8 g) (with a tolerance of +0.03 (0.8 g, -0 oz) from a height of 50 in. (1.3 m) upon the horizontal upper surface of the toy in the area that would cover the eyes in normal use. In the case of toys with cutout eye holes, impact the area that would be directly adjacent to the eyes in normal use. The ball may be guided, but not restricted, in its fall by being dropped through a perforated tube extending to within approximately 4 in. (100 mm) of the toy.

8.8 *Torque Tests for Removal of Components*—Any toy with a projection, part, or assembly that a child can grasp with at least the thumb and forefinger or the teeth shall be subject to this test. The amount of torque shall be determined from Table 5, according to the age group for which the toy is intended. The loading device used in the test shall be a torque gauge, torque wrench, or other appropriate device having an accuracy of ± 0.2 in.·lbf (± 0.02 N·m). A clamp capable of holding the test

component firmly and transmitting a torsional force shall be used. The clamp is fastened to the test object or component with the toy fastened rigidly in any reasonable test position. The torque shall be applied evenly within a period of 5 s in a clockwise direction until either (1) a rotation of 180° from the original position has been attained, or (2) the required torque is exceeded. The maximum rotation or required torque shall be maintained for an additional 10 s. The torque shall then be removed and the test component permitted to return to a relaxed condition. This procedure shall then be repeated in a counterclockwise direction. Projections, parts, or assemblies that are mounted rigidly on an accessible rod or shaft designed to rotate along with the projections, parts, or assemblies shall be tested with the rod or shaft clamped to prevent rotation. If a component that is attached by a screw thread that has been assembled by the manufacturer, or that has been assembled to the manufacturer's instructions, becomes loosened during application of the required torque, continue to apply the torque until either (1) the required torque is exceeded, or (2) the part disassembles. The test should be terminated if it becomes obvious that the part under test will continue to rotate at less than the required torque limit and will not disassemble.

8.8.1 If the part disassembles, evaluate it for compliance with the appropriate requirements. If the disassembly exposes an accessible component that can be grasped as noted above, repeat the torque test on that component.

8.9 *Tension Test for Removal of Components*—Any projection of a toy that a child can grasp with at least the thumb and forefinger or the teeth shall be subjected to this test. The tension test shall be performed on the same components of the toy subjected to the torque test described in 8.8. The amount of force used shall be determined from Table 5, according to the age group for which the toy is intended. A clamp capable of applying a tension load to the test component shall be applied in a manner that will not affect the structural integrity of the attachment between the component and the toy. The loading device shall be a self-indicating gauge or other appropriate means having an accuracy of ± 0.5 lb (± 2 N). With the test sample fastened in a convenient position, an appropriate clamp shall be attached to the test object or component. The required tensile force shall be applied evenly, within a period of 5 s, parallel to the major axis of the test component, and maintained for an additional 10 s. The tension clamp shall then be removed, and a second clamp suitable for applying a tension load perpendicularly to the major axis of the test component shall be attached to the test object component. The required tensile force shall be applied evenly, within a period of 5 s, perpendicularly to the major axis of the test component and maintained for an additional 10 s.

8.9.1 *Tension Test for Seams in Stuffed Toys and Beanbag-Type Toys*—A stuffed toy or beanbag constructed of pliable material having seams (including, but not limited to, seams that are stitched, glued, heat sealed, or ultrasonic welded) shall have the seams subjected to a separate tension test in any direction using the forces specified in 8.9 and determined from Table 5 according to the age group for which the toy is intended.

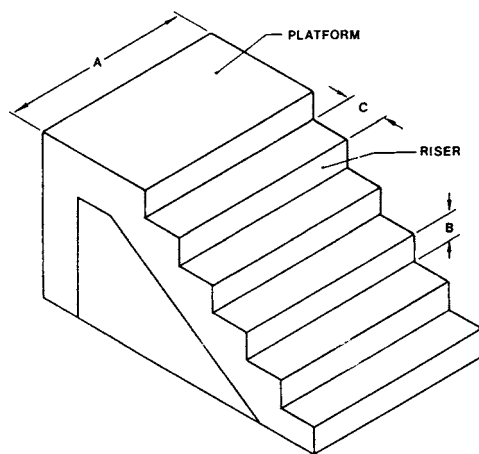

Dimensions

"A" shall be not less than 3 ft (914 mm)

"B" shall be not less than 7 in. (180 mm)

"C" shall be not more than 9 in. (230 mm)

FIG. 26 Illustration of Step Construction

8.9.1.1 The clamps used to grip the material on either side of the seam to be tested shall have jaws to which are attached 3/4-in. (19-mm) diameter washers (see Fig. 27). The clamps shall be attached to the cover material of a completely assembled stuffed toy in a manner such that the outside diameter of the 3/4-in. (19-mm) washers at a point nearest the seam shall be close to, but no closer than, 1/2 in. (13 mm) from the edge of the seam stitching thread. This seam test shall not be performed if the material adjacent to the seam cannot be grasped between the thumb and forefinger of the test personnel sufficient for full clamping by the 3/4-in. (19-mm) diameter washer jaws. If such is the case, a torque and tension test shall be performed on an arm, leg, or other appendage of the toy instead of the seam test.

8.9.1.2 In performing a seam test, the force appropriate for the age category into which the toy falls (see Table 5) shall be applied evenly within 5 s and maintained for an additional 10 s.

8.10 *Compression Test*—Any area on the surface of a toy that is accessible to a child and inaccessible to flat surface contact during the impact test shall be subject to this test. The compression force shall be determined from Table 5 according to the age group for which the toy is intended.

8.10.1 The loading device shall be a rigid metal disk 1.125 ± 0.015 in. (0.380 mm) in diameter and 0.375 in. (9.52 mm) in thickness. The perimeter of the disk shall be rounded to a radius of 1/32 in. (0.8 mm) to eliminate irregular edge. The disk shall be attached to an appropriate compression scale having an accuracy of ±0.5 lb (2 N). The disk shall be positioned so that the flat contact surface is parallel to the surface under test. The required force shall be applied evenly within 5 s through the disk. This load shall be maintained for an additional 10 s. The toy is to rest on a flat, hard surface in any convenient position during the test.

8.11 *Tests for Tire Removal and Snap-in Wheel and Axle Assembly Removal*—These tests relate to the requirements of 4.17.

8.11.1 *Removal of Tires*—The toy shall be clamped so that the wheel axle is vertical. A wire hook shaped as shown in Fig. 28 shall be positioned on the lower tire and attached to a dead weight of 10 ± 0.5 lb (4.5 kg) if the tire is on a toy intended for children aged 18 months or less, or to a dead weight of 15

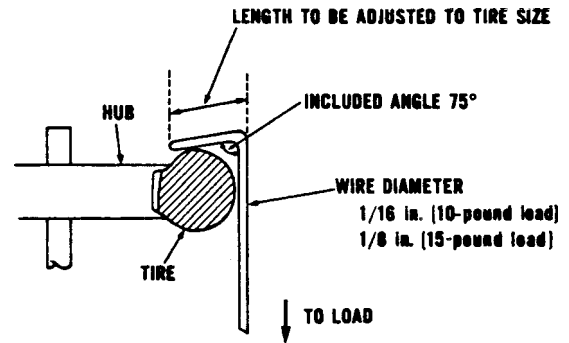

FIG. 28 Hook for Tire Removal

± 0.5 lb (6.8 kg) if the tire is on a toy intended for children aged over 18 months but not over 36 months. The load shall be applied gradually over a period of 5 s and maintained for 10 s.

8.11.2 *Toys Assembled With Snap-in Axles*—A 15 ± 0.5-lb (6.8-kg) dead weight shall be applied perpendicularly to the axle and in the least favorable direction, adjacent to a bearing (but between the two bearings), for 10 s, using a hook and string for attachment to the toy. The toy shall be held horizontally in a test-convenient fixture, and the load shall be applied gradually over a 5-s period and then shall be maintained for 10 s. The toy shall be held horizontally if the axle cannot be hooked as described above, and a 10 ± 0.5-lb (4.5-kg) dead weight shall be attached to one wheel by means of a hook or clamp that acts perpendicular to the axle in the least favorable direction. The load shall be applied gradually over a 5-s period and then be maintained for 10 s.

8.11.3 *Compression Test for Snap-in Wheel and Axle Assemblies*—This test is for determining compliance with 4.17 if the axle and wheel are removed by the procedure described in 8.11.2. The wheel and axle assembly shall be positioned with the axle vertical over a hole in a rigid plate, as shown in Fig. 29. The hole shall be large enough in diameter to permit the axle to pass through. A load of 20 ± 0.5 lb (89 N) is applied to the upper wheel, using a suitable circular adaptor to prevent interference with the axle. The load shall be applied gradually over a 5-s period and then shall be maintained for 10 s. When applying the load, the upper wheel shall be guided, if necessary, in order to maintain the axle in a vertical position, but it shall not be restrained from moving downward. The axle shall

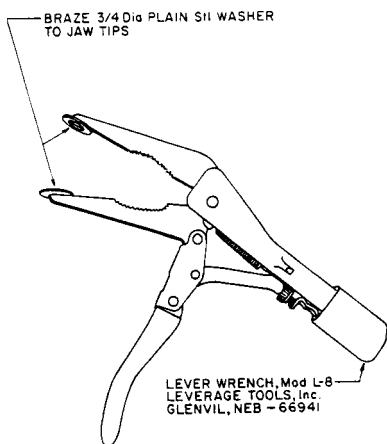

FIG. 27 Seam Clamp

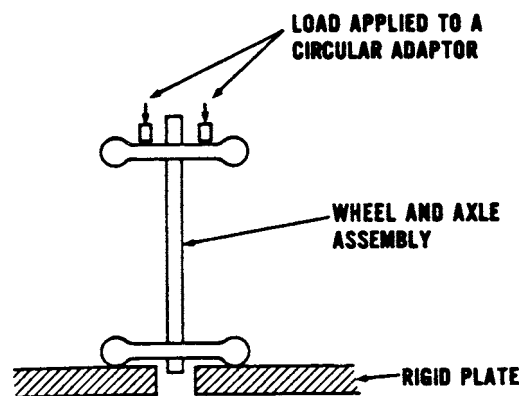

FIG. 29 Compression Test for Wheel Assemblies

not form a hazardous point or projection in those cases in which it is forced through either wheel.

8.12 *Flexure Test*—This test is for determining compliance with 4.10, for wires or rods used as flexible skeletons. The toy shall be secured in a vise equipped with vise shields that are fabricated from 13-gauge thick cold-rolled steel or other similar material and that have a 0.375-in. (9.5-mm) inside radius as shown in Fig. 30. The component shall then be bent through a 60° arc by a force applied perpendicularly to the major axis of the component at a point 2 ± 0.05 in. (50 mm) from the intersection of the component with the main body of the toy or applied at the end of the component if the component is less than 2 in. (50 mm) long. The force shall be determined from Table 5. The component shall then be bent in the reverse direction through a 120° arc. This process shall be repeated for 30 cycles at a rate of 1 cycle/2 s, with a 60-s rest period occurring after each 10 cycles. Two 120° arc bends shall constitute one cycle.

8.13 *Test for Mouth-Actuated Toys*—A piston pump capable of discharging and taking in more than 18 in.³ (295 cm³) of air in less than 3 s shall be connected to the mouthpiece of the toy. A relief valve shall be so arranged that the pump will not generate a positive or negative pressure of more than 2 psig. The toy shall be subjected to 10 alternating blowing-and-sucking cycles of at least 18 in.³ (295 cm³) of air, including that volume that may be discharged through the relief valve. Any objects released as a result of this test shall be inspected for conformance with 4.6. The above procedure shall also be applied to the outlet if the air outlet of the toy is accessible as described in 4.6.2.

8.14 *Projectiles:*

8.14.1 *Kinetic Energy Determination*—The kinetic energy of a projectile as defined in 3.1.51 shall be determined from the following equation:

$$\text{kinetic energy} = 1/2 mv^2 \quad (1)$$

where:

- m = mass of projectile, kg, and
- v = velocity of the projectile, m/s.

8.14.2 The mass of a projectile, m , shall be determined by weighing a sample on a laboratory balance. The velocity of a projectile, v , shall be determined by firing a sample from the discharge mechanism of the toy across ballistic screens placed a known distance apart (s , metres) and recording the time (t ,

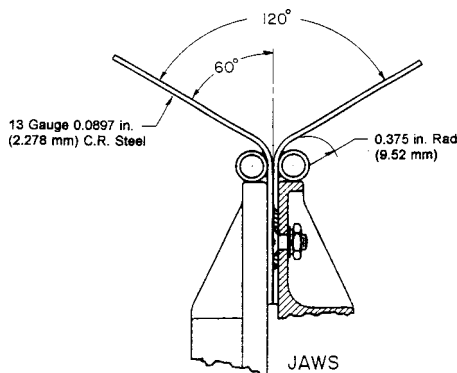

FIG. 30 Flexure Tester

seconds) to travel that distance. The velocity of the projectile shall be calculated from the expression $v = s/t$ m/s.

8.14.3 When performing the test to measure the velocity of a projectile, the second screen shall be placed a distance no more than 1 ft (300 mm) plus one projectile length from the point at which the entire projectile enters free flight (see Fig. 31). Due to the flight characteristics of certain projectiles and other factors that may influence the accuracy of the measurement of projectile velocity, the value of v in the equation for kinetic energy shall be the average of five measurements.

8.14.4 *Impact Test for Projectiles*—Projectiles, as defined in 3.1.59, shall be propelled by their discharge mechanism three times into a concrete block wall (or equivalent surface) located at a distance 1 ft (300 mm) plus the length of the projectile from the front end of the launcher. The discharge mechanism shall be aimed perpendicular to the wall.

8.15 *Test for Stability of Ride-On Toys or Toy Seats*—These tests relate to the requirements of 4.15.

8.15.1 Place the ride-on toy or toy seat across the slope of a smooth surface inclined 10° to the horizontal plane. (Some tests require a 15° slope; refer to 4.15.2.2 and 4.15.3.)

8.15.2 Turn the steering mechanism, if any, to a position at which the ride-on toy or toy seat is most likely to tip.

8.15.3 Chock any wheels to restrict rolling, but allow casters to assume their natural position before chocks are applied.

8.15.4 Apply to the seat a static load equal to the weight indicated in Table 6 at the highest age of the age range for which the ride-on toy or toy seat is intended, but not exceeding 60 months. When the highest age of the intended age range falls between two ages listed in Table 6, the higher of the two shall be chosen.

8.15.5 The load shall be applied so that the major axis is perpendicular to the true horizontal while the ride-on toy or toy seat is on the incline specified.

8.15.6 The load shall be designed so that the height of its center of gravity is 8.7 ± 0.5 in. (220 ± 13 mm).

8.15.7 The center of gravity of the load for the sideways stability test shall be secured to the geometric center of the designated seating area.

NOTE 15—Separate tests for each side.

8.15.8 If there is no designated seating area or if there is no designated sideways orientation, the load shall be placed 1.7 in. (43 mm) inward towards the geometric center of the ride-on toy or toy seat from the least favorable position that it is reasonable to anticipate that the child will choose to sit (note - separate tests for each side).

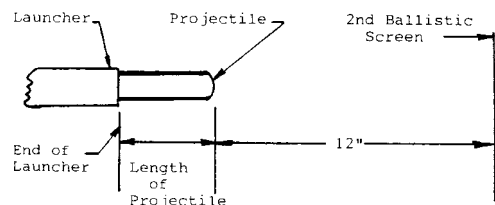

NOTE 1—First ballistic screen to be located between end of launcher and second screen.

FIG. 31 Diagram of Layout to Determine Projectile Velocity

TABLE 6 Weight of 95th Percentile Children (Values Given for Boys or Girls, Whichever is Higher)

Age, years	Weight, lb (kg)
1	28 (12.6)
2	29 (13.2)
3	42 (18.9)
4	43 (19.7)
5	50 (22.6)
6	59 (26.6)
7	69 (31.2)
8	81 (37.0)
9	89 (40.4)
10	105 (47.9)
11	121 (55.0)
12	120 (54.7)
13	140 (63.6)
14	153 (69.6)

NOTE 16—Separate tests for each side.

8.15.9 The center of gravity of the load for the fore and aft stability test shall be secured both 1.7 in. (43 mm) rearward of the front-most portion of the designated seating area and 1.7 in. (43 mm) forward of the rear-most portion of the designated seating area.

NOTE 17—Two separate tests.

8.15.10 If there is no designated seating area or if there is no designated fore and aft orientation, the load shall be placed 1.7 in. (43 mm) inward towards the geometric center of the ride-on toy or toy seat from the least favorable position that it is reasonable to anticipate that the child will choose to sit.

NOTE 18—Two separate tests.

8.16 Pompoms are subjected to the torque test as described in 8.8 and 8.8.1 and the tension test as described herein. The clamps used to grip the material to be tested shall have jaws to which 3/4-in. (19-mm) diameter washers are attached (see Fig. 27). One clamp shall be attached to the pompom and a second clamp used to grip the base material. A force of 15 lbf (67 N) shall be applied evenly within 5 s and maintained for an additional 10 s.

8.17 *Stalled Motor Test for Battery-Operated Toys:*

8.17.1 The test shall be conducted using a new toy. Each motor shall be tested separately using fresh alkaline batteries. If another battery chemistry is specifically recommended for use in the toy by the manufacturer, repeat the test using the batteries specified by the manufacturer. If the toy will not operate using alkaline batteries, test with the type of battery recommended by the manufacturer at the specified voltage. The test is to be carried out in a draft-free location at an ambient temperature of 20 ± 5°C.

8.17.2 Operate the toy with moving parts that are mechanically linked to a motor locked in a fixed position. Only lock moving parts which can be stalled external to the toy. Do not disable any mechanical or electrical protective device such as clutches or fuses. Monitor the temperatures with the toy fully assembled. If normal use allows the motor to run unattended or if the toy has a non-recessed switch allowing it to be kept in the “on” position, operate the toy continuously and record the maximum temperatures. The test may be discontinued 60 min

after the peak temperature of each component being tested is recorded. If the toy shuts off automatically or must be kept “on” by hand or foot, monitor temperatures for 30 s, resetting the toy as many times as necessary to complete the 30 s of operation. If the toy shuts off automatically after an operating time of greater than 30 s, continue the test until the toy shuts off. At the conclusion of the test, the stalled motor condition shall not cause temperatures to exceed the limits of 4.25.7, or cause battery leakage, an explosion, or a fire.

8.18 *Tests for Battery-Powered Ride-on Toys:*

8.18.1 Components tested in accordance with the following sections are to be installed and operated in the toy, as they would be during normal use unless otherwise specified. Testing is to be conducted using fully charged batteries.¹⁶

8.18.2 *Maximum Temperature Test:*

8.18.2.1 Mechanically precondition all electrical pressure connections used for charging or discharging the battery(ies). If a main harness connector is provided, the main harness connection must be connected and disconnected 600 times before the Maximum Temperature Test is performed. If a user replaceable fuse is provided, remove and insert the fuse 25 times before the Maximum Temperature test is performed.

8.18.2.2 Power the test sample using a fully charged battery as specified by the manufacturer. Operate the vehicle in the mode that results in the maximum continuous current draw. Determine the maximum continuous current draw by testing the vehicle on any intended surface as specified by the manufacturer, and by adjusting the weight, up to the manufacturer specified maximum. Several trials on different surfaces and with different weights may be necessary to determine the maximum continuous current draw.

8.18.2.3 Physically load the vehicle in any way necessary to obtain the maximum continuous current draw. Operate the vehicle continuously until the battery is exhausted or until thermal equilibrium is reached. If thermal equilibrium is not reached, replace the battery with a fully charged battery and continue the test.

8.18.3 *Stalled Motor Test for Battery-Powered Ride-on Toys*—Mechanically lock any accessible motor driven parts. For toys having more than one motor, each motor shall be tested individually. For toys having more than one operating mode, a different toy shall be tested in each mode. The toy shall be entirely draped with a double layer of cheesecloth during the test. For motors or other electrical components that are accessible, the cheesecloth shall also be draped over the component.

8.18.3.1 Operate the toy, under the stalled condition, until a circuit protection device interrupts the current or until the battery is depleted.

8.18.3.2 If the circuit protection device interrupts the circuit, immediately reset the circuit protection device or replace it in the case of a fuse and repeat the test three more times. If

¹⁶ Testing is to be conducted while the vehicle is operated on a hard level surface covered with 3M #610 General Purpose Safety Walk tape or equivalent surface with a coefficient of friction between 1.27 and 1.32 when measured in accordance with MIL-D-17951. Cheesecloth referenced in the following tests is #60 cotton gauze with a thread count of 32 by 28 threads per inch.

the circuit protection device automatically resets, continue the stalled motor test until the battery is exhausted.

8.18.3.3 The test shall not result in ignition of the cheesecloth.

8.18.4 *Nuisance Tripping Test*—Conduct the tests on a level surface as specified in 8.18.1, loading the vehicle with the maximum weight specified by the manufacturer.

8.18.4.1 *Start/Stop Condition*—Start and stop the toy in 1-s cycles for 30 repetitions (0.5 s start followed by 0.5 s stop) in the mode that draws the greatest current.

8.18.4.2 *Forward/Reverse*—If the toy has a reverse direction feature, cycle the toy in the forward and reverse directions in 1-s cycles for 30 repetitions (0.5 s forward followed by 0.5 s reverse) in the mode that draws the greatest current.

8.18.5 *Switch Endurance and Overload Tests*—Precondition switches at 95 % relative humidity between 20°C and 32°C for 48 h. Conduct the Switch Endurance and Overload Tests at 40°C. A switch is to be operated by means of its actuating member either manually or by mechanical means making and breaking the test current. If a fuse or protective device operates (opens or trips) the device must be replaced or reset as many times as necessary to complete the required number of cycles. The test may be concluded at less than the prescribed number of cycles if the switch fails safe (switch stuck in the “off” position and no short-circuit condition results). Test 3 samples. All samples must pass.

8.18.5.1 *Switch Endurance Test*—If a switch is relied upon for starting and stopping of the vehicle, conduct the endurance test for 100 000 cycles. Cycle (minimum 1 s on time and at least 6 cycles per minute) a switch in the toy using the maximum continuous current load as determined in the Maximum Temperature Test or in an equivalent simulated motor load circuit including the inrush and inductive characteristics. All other switches are to be subjected to 6000 cycles of endurance testing. Cycle (minimum 1 s on time and at least 6 cycles per minute) a switch in the toy using the maximum continuous current load as determined in the Maximum Temperature Test or in an equivalent simulated motor load circuit including the inrush and inductive characteristics.

8.18.5.2 *Switch Overload Test*—The overload test is to be conducted on a switch that is relied upon for starting and stopping of the vehicle. Stall the motor(s) of the toy. Operate the switch for 50 cycles of operation at a rate of 6 cycles per minute with 1 s on and 9 s off.

8.18.6 *Battery Overcharge Test*—Each battery shall be charged with its intended charger continuously for 336 h. The test shall not result in the release of electrolyte, or cause explosion or fire.

8.18.6.1 If the battery can be charged in the vehicle, place the battery in the vehicle and connect it to the charging circuit. Drape the charger, cable, and battery with a double layer of cheesecloth. The test shall not result in ignition of the cheesecloth or in the release of electrolyte.

8.18.7 *Short-Circuit Protection Test*—Entirely drape the toy with a double layer of cheesecloth. Short-circuit parts of opposite polarity. Any possible short-circuit condition shall not result in ignition of the cheesecloth.

8.18.8 *Strain Relief Test*—The electrical connections of the cord or harness are to be disconnected. Apply a 20 lbf (90 N) to the cord so that the strain relief will be stressed from any angle permitted by the construction of the toy. Maintain the specified force for 1 min. There shall be no movement of the cord to indicate stress on the connections.

8.19 *Tests for Toys Which Produce Noise:*

8.19.1 *Installation and Mounting Conditions:*

8.19.1.1 *General*—Carry out the measurements on a new toy not already subjected to testing. Test battery toys using new primary batteries or fully charged secondary batteries. External power supplies should not be used as they will, in many cases, affect the performance of the toy.

8.19.1.2 *Test Environment*—Any environment that meets the qualification requirements of ISO 3746, Annex A.

NOTE 19—In practice, this means that most normally furnished rooms with a volume exceeding 30 m³ will qualify at measurement distances of 50 cm provided that the largest dimension of the toy does not exceed 50 cm.

8.19.1.3 *Mounting*—Test rigs used for the mounting of toys and/or the operator of the toy shall not affect the sound emission of the toy under test nor cause sound reflections which will increase the sound pressure levels at the measuring points.

(1) Mount close to the ear toys and hand-held toys in a proper test rig at least 100 cm above the reflecting plane or have them operated by an adult operator with the arm outstretched.

(2) Place stationary table top, floor, and crib toys on a standard test table as described in ISO 11202. A table with a wooden top with a thickness of 4 cm or larger and leg construction providing a stable test surface is considered sufficient. The table top should be large enough such that, with the toy resting on and fully over the table top, the side of the measurement box from which the measurement is being made is also above the table top (see 8.19.2.3(5)).

(3) Mount self propelled table top and floor toys on the standard test table described above in a test rig so that they can be operated with full power, but preventing them from moving around.

(4) Place pull and push toys on the reflecting plane (for example, concrete, tile, or other hard surface) and fix them in a test rig which enables them to be moved with varying speed along a direct line which passes the measuring microphones (“passing by” test). Make sure that the friction of the reflecting plane prevents wheels from skidding.

(5) Place hand-actuated wind-up toys, with the wind-up spring fully loaded, on the reflecting plane (for example, concrete, tile, or other hard surface) so that the front of the toy is 40 ± 1 cm along the *x*-axis from the microphones of the “passing by” test (see Fig. 32).

(6) Mount other types of toys in the most appropriate way using the principles described in previous paragraphs.

8.19.1.4 *Operating Conditions*—Operate the toy under test in that mode of its intended or foreseeable use that produces the highest sound pressure level to the microphone position, where the maximum noise level is observed. In particular:

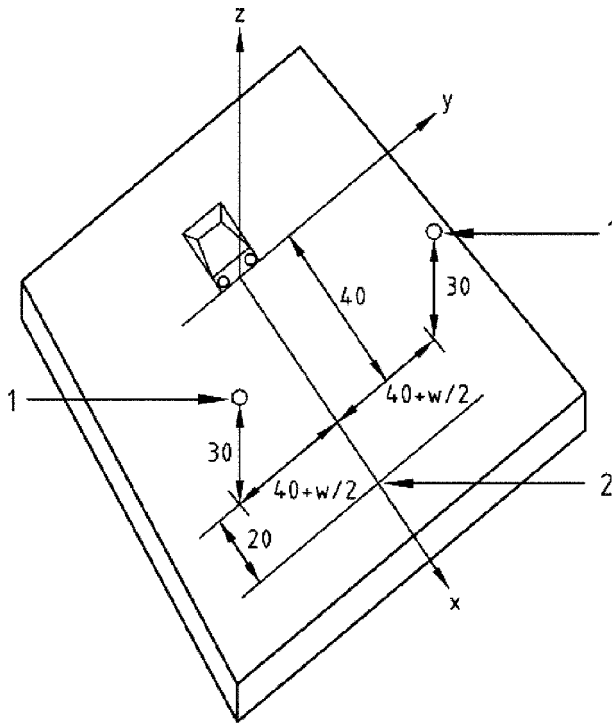

NOTE—

Key:

1—Microphone

2—End of measurement

w—width of toy

FIG. 32 Microphone Positions for Measurements of Pull and Push Toys and for Hand-Actuated Spring-Propelled Toys (“Pass-by” Test)

(1) Operate a hand-actuated toy manually, excluding pull and push toys, by applying the force at the point and direction of its intended or foreseeable use giving the maximum sound pressure level. For a toy intended to be shaken, shake at a rate of three times per second. One cycle shall consist of an initial 15 cm stroke followed by a return to the starting point.

(2) Operate a rattle by grasping it where it is meant to be held or, if in doubt, where the longest lever between the hand and the sound emitting part of the rattle can be obtained. Make sure that the radiated sound is not affected by the grip of the hand. Strike downwards ten times with hard lashes in a slow tempo. Use the wrist and keep the forearm essentially horizontal. Endeavour to achieve the highest possible sound level. Stand side-face with the microphone and keep the rattle at the same height as the microphone at a distance of 50 cm.

(3) Operate a pull and push toy at a speed that yields the maximum sound pressure level. Do not exceed 2 m/s.

(4) Operate a cap-firing toy using percussion caps recommended by the manufacturer and which are available on the market.

8.19.2 Measurement Procedure:

8.19.2.1 Basic International Standards to be Used—The minimum requirement is to determine sound pressure levels at the specified positions around the toy in accordance with ISO 11202 or ISO 11204.

8.19.2.2 Instrumentation—The instrumentation system, including the microphone and cable, shall meet the requirements of a class 1 or class 2 instrument specified in IEC 61672-1 and IEC 61672-2. When measuring high peak sound pressure levels, for example, from toys using percussion caps, the microphone and the entire instrumentation system shall have the capability of handling linear peak levels exceeding the C-weighted peak levels by at least 10 dB.

8.19.2.3 Microphone Positions—General—Several microphone positions shall be used. In practice, this often means that one microphone is moved from position to position. Whenever it is practicable, it is always an alternative to rotate the test object instead. Attention must be paid to maintaining the correct measuring distance.

(1) Close-to-the-Ear Toys—To measure continuous sounds, face the earpiece of the toy at the microphone with the microphone 50 ± 0.5 cm from the earpiece. To measure continuous sounds on toys without earpieces, locate the microphone 50 ± 0.5 cm from the surface of the toy where the main sound source exists such that the sound pressure level at the microphone is maximized. To measure impulsive sounds, locate the microphone 50 ± 0.5 cm from the surface of the toy where the main sound source exists such that the sound pressure level at the microphone is maximized.

(2) Cap-Firing Toys—Use six microphone positions around the toy. Place the main sound emitting part of the toy at the origin of the measuring coordinate system in its normal operating orientation in such a way that the main axes of the toy coincide with the axes of the measuring coordinate system (see Fig. 33). If the length of the toy exceeds 50 cm, rotate the toy in the xy -plane 45° around the z -axis without changing the microphone positions. Select two microphone positions along each axis at a distance of 50 ± 1 cm to both directions from the origin as shown in Fig. 33.

(3) Rattles—Mount the microphone 1.2 m above the floor and at a distance of 0.5 m from the sound source.

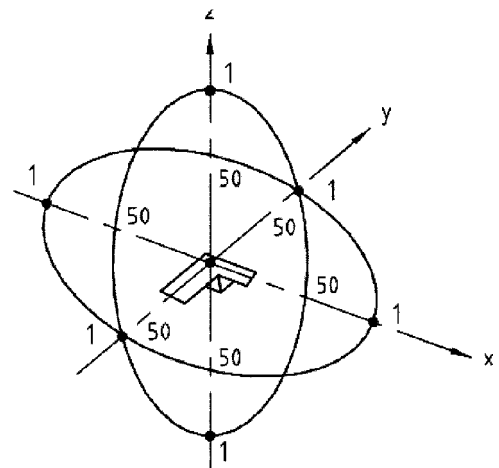

NOTE—

Key:

1—Microphone

FIG. 33 Microphone Positions for Measurement of Sound Pressure Levels of Cap Firing Toys

(4) *Other Hand-Held Toys*—Select six microphone positions on a box-shaped measurement surface at the measuring distance of 50 cm from the reference box of the toy, as defined in ISO 3746, as specified in Fig. 34. The positions are at the centers of the sides of the measurement surface at the distance 50 cm from the reference box.

(5) *Stationary and Self-Propelled Table-Top, Floor, and Crib Toys*—Select five, or if the length or width of the toy is larger than 100 cm, nine microphone positions on a box-shaped measurement surface at the measuring distance of 50 cm from the reference box of the toy as specified in Fig. 35. The sides of the measurement box with height H are always 50 cm from the sides of the reference box, except for the bottom of the boxes, which lie in the same plane. All microphone positions are on the measurement box.

(6) *Pull and Push Toys and Hand-Activated Spring-Propelled Toys*—For toys with a width (w) of 25 cm or less, use two microphones at distances (d) 50 cm from the x -axis of the measuring coordinate system as shown in Fig. 32. For toys with a width (w) of more than 25 cm, use two microphone at distances (d) 40 cm plus half the width of the toy from the x -axis ($40 + w/2$) as shown in Fig. 32. Place the toy on a test rig or on the reflecting plane in its normal operating orientation in such a way that movement of the toy is possible along the x -axis passing the microphone positions.

8.19.2.4 Measurements:

(1) *General*—Normal operating mode(s) shall be reached before the tests are performed.

(2) *Measurements of Continuous Sounds*—If the toy under test has a clearly defined operating cycle, measure the equivalent sound pressure level in each microphone position during at least one whole cycle. Quiet periods longer than 15 s shall be excluded from the measurement period. Perform a total of three measurements. If the toy under test does not have a clearly defined operating cycle, measure the equivalent sound pressure level in each microphone position for at least 15 s during the operational mode where the noise level is highest. Perform a total of three measurements.

(3) *Measurements of Impulsive Sounds*—Measure the C-weighted peak sound pressure level, L_{Cpeak} , of impulsive

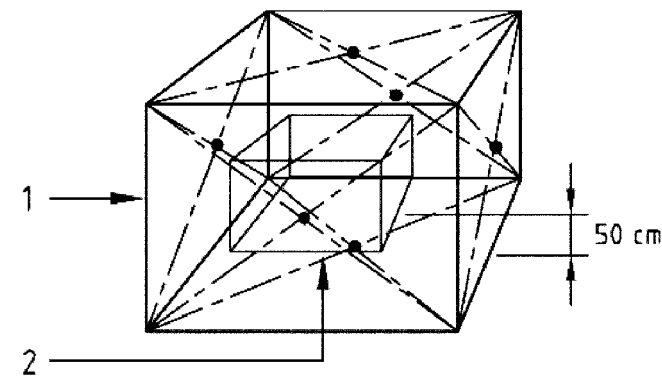

NOTE—
Key:
1—Measurement box
2—Reference box

FIG. 34 Microphone Positions for All Other Hand-Held Toys

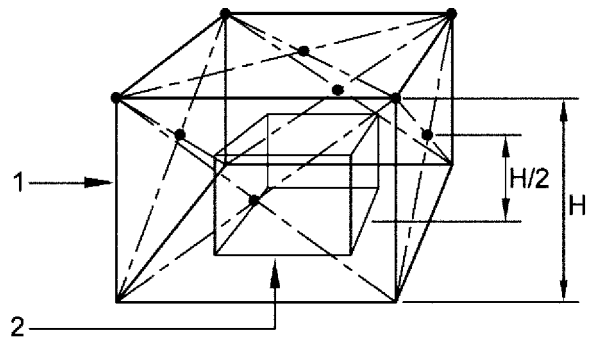

NOTE—
Key:
1—Measurement box
2—Reference box

FIG. 35 Microphone Positions for Measurement of Stationary and Self-Propelled Table-Top, Floor, and Crib Toys

sounds in each microphone position. Perform a total of three measurements. For pass-by tests, measure the C-weighted peak sound pressure level. Measure twice on each side.

(4) *Measurement for Rattles*—Measure the C-weighted peak sound pressure level, L_{Cpeak} , for ten cycles. Perform a total of three measurements.

(5) *Measurement Results*—Sound measurement results shall be given as: (a) A-weighted equivalent sound pressure level at the specified position, L_{Aeq} , in decibels; (b) C-weighted peak sound pressure level at the specified position, L_{Cpeak} , in decibels.

(6) The highest value of the applicable measurements (L_{Aeq} and L_{Cpeak}) at any of the microphone positions is the measurement result.

8.20 *Dynamic Strength Test for Wheeled Ride-on Toys*—Load the toy for 5 min in the most onerous position with the appropriate mass in accordance with Table 6 on its standing or sitting surface. Secure the load to the toy in a position corresponding to the normal use of the toy. Drive the toy three times at a speed of 6.6 ft/s (2 m/s) \pm 0.7 ft/s (0.2 m/s) into a nonresilient step with a height of 2 in. (50 mm). If the toy is intended to bear the mass of more than one child at a time, test each sitting or standing area simultaneously. Determine whether the toy continues to conform to the relevant requirements of this specification.

8.21 *Plastic Film Thickness*—Use a measuring device (dial-type thickness gauge or equivalent) capable of measuring thickness to an accuracy of 4 μ m. Measurements shall be taken at 10 equidistant points across the diagonal of any 3.94 by 3.94-in. (100 by 100-mm) area. For plastic bags, prepare by cutting the sides, without stretching, into two single sheets.

8.22 *Test for Loops and Cords:*

8.22.1 *Anchor or secure the toy.* Place the head probe (Fig. 10) in the loop/opening formed by the cord/s, tapered end first, with the plane of its base parallel to the plane of the opening. Rotate the probe to any orientation about its own axis while keeping its base parallel to the plane of the opening; apply 10 lbf (45 N) while attempting to push the probe through the opening.

8.22.2 Elastic materials or loops that are smaller than the tapered diameter of the head probe shall be stretched before applying the head probe test fixture using the hook test fixture illustrated in Fig. 36. To begin the evaluation, the elastic material is first looped around the left bottom hook, then hooking the elastic material with the hook attachment of the force gauge, pull the elastic material to the right bottom hook without exceeding a force of 5.0 lbf (22.2 N). The elastic material is then pulled to the left upper hook without exceeding a force of 5.0 lbf (22.2 N). Pull the elastic material to the right side so that the hook of the force gauge is adjacent to the left upper hook and parallel to the right bottom hook without exceeding a force of 5.0 lbf (22.2 N). The hook of the force gauge should remain in this position during testing. If the elastic material cannot be stretched and held in this position or if the force needed to stretch the elastic material exceeds 5.0 lbf (22.2 N), the elastic material complies with this requirement. The testing sequence is illustrated in Fig. 36 (a) through (e). If the body of the toy forms part of the loop, position the body of the toy so that it is on the open, right-hand side of the hook test fixture. Apply the head probe in accordance with 8.22.1.

8.22.3 For cords, straps, and elastics that form loops and have a perimeter larger than the base diameter of the head probe and contain a breakaway feature, the following test is applied to determine release force. With the cord secured in a vertical fashion so that the breakaway feature is essentially in the center of the two clamping devices, apply a downward

force and determine if the breakaway feature releases at a force less than 5.0 lbf (22.2 N).

8.23 *Yo Yo Elastic Tether Toy Test Methods:*

8.23.1 The yo yo elastic tether toy is tested in its most onerous foreseeable use configuration. Hold the yo yo elastic tether toy by whatever holding means is supplied, typically a small loop. Rotate the toy in a horizontal or near-horizontal plane using any convenient means to achieve a constant rotational speed of 80 r/min or the maximum achievable speed up to 80 r/min.

NOTE 20—The plane of rotation may not be horizontal given the physical characteristics of the toy, for example the size and mass of the object at the end of the tether.

NOTE 21—Where a tether has no distinct holding means, such as a finger loop, the unloaded length of the tether that is held should be the minimal length required to prevent release of the tether during rotation.

8.23.1.1 A variable speed drill is one method of achieving a constant rotational speed. If such a drill is used, attach the holding means to a rigid cam as shown in Fig. 37. Use a cam of 3 cm (1.18 in.) in length as measured from the center of rotation to the edge of the clamping mechanism furthest from the center of rotation (see Fig. 38). If necessary, manually start the product rotating. A typical test set up is shown in Fig. 37.

8.23.2 Measure the length of the tether when the tether is fully extended during rotation. There is no requirement to measure the exact length of a tether if its fully extended length during rotation is well below or well beyond 50 cm (20 in.) (for

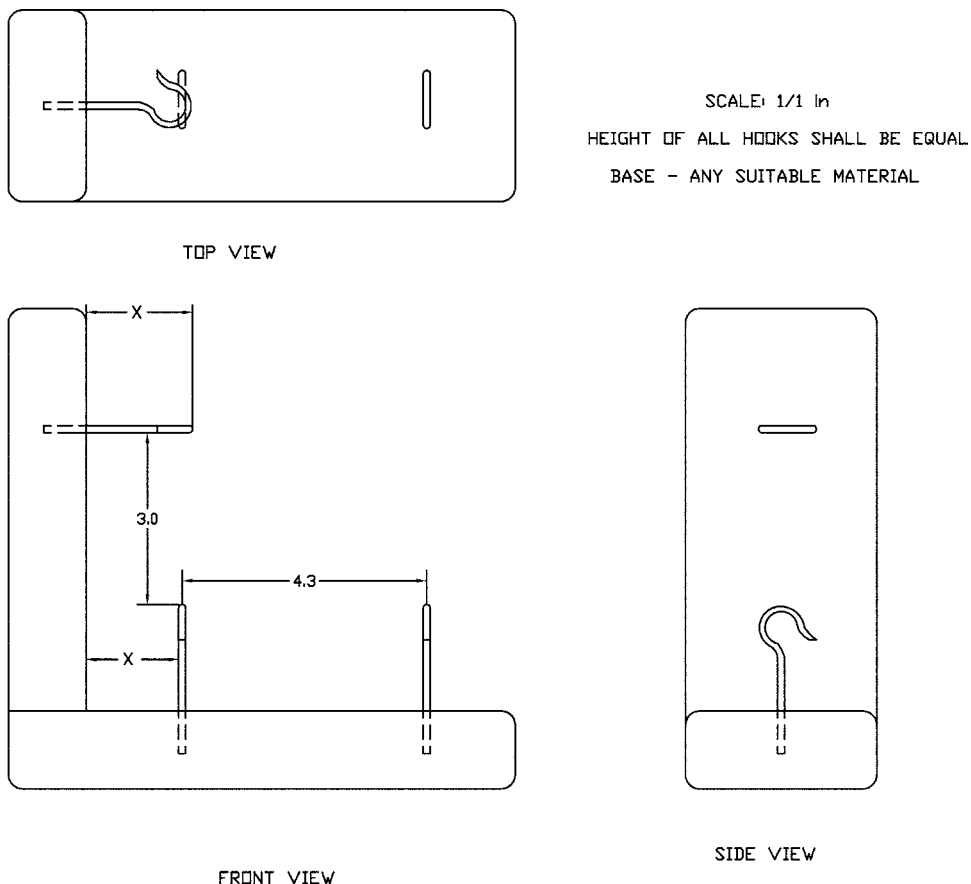

FIG. 36 Hook Test Fixture for Cords and Loops

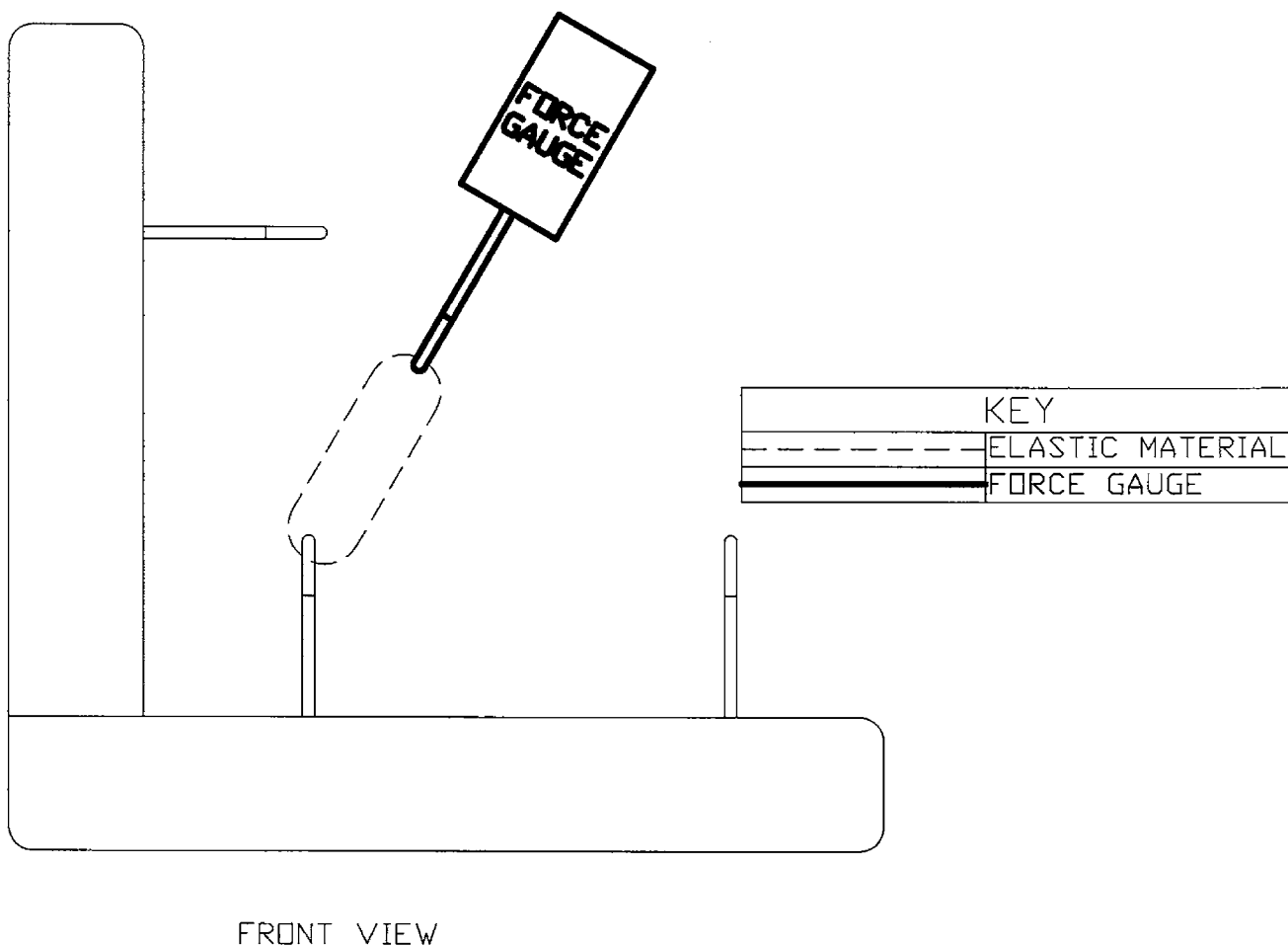

FIG. 36 (a) Test Procedure for Cords and Loops, Step 1 (continued)

example, less than 40 cm (16 in.) or greater than 60 cm (24 in.)). The tether length does not include the length of the mass at the end, the holding means (if present), or the cam (if used).

8.23.2.1 To facilitate length measurement of the tether during rotation, if helpful, mark two points along its length when it is under no load: (1) the point where it joins the mass at the end and (2) the point where it joins the holding means, as shown in Fig. 39.

8.24 Magnet Test Methods:

8.24.1 Flux Density Measurement:

8.24.1.1 Test Equipment—dc field gauss meter with a resolution of 5 gauss (G) and an axial type probe.

(1) An active area diameter of 0.76 ± 0.13 mm.

(2) A distance between the active area and probe tip of 0.38 ± 0.13 mm.

8.24.1.2 Test Method:

(1) Place the probe's tip in contact with the pole surface of the magnet. For a magnetic component (where the magnet is fully or partially imbedded in part of the toy), place the probe's tip in contact with the surface of the component.

(2) Keep the gauss meter's probe perpendicular to the surface.

(3) Move the probe across the surface to locate the maximum absolute flux density.

(4) Record the maximum absolute flux density measurement.

8.24.2 Area Measurement of the Pole Surface:

8.24.2.1 Test Equipment—Calipers or similar device with a resolution of 0.1 mm.

8.24.2.2 Test Method—If the magnet is imbedded/attached as part of a magnetic component, extract the magnet from the component. If the pole surface of the magnet is flat, calculate the area using the appropriate geometric formula. If the pole is not flat (for example, hemispherical), the pole surface area is the maximum cross section of the magnet perpendicular to an axis through the magnet poles (see Fig. 40).

NOTE 22—On multi-pole magnets use the area of the largest single pole, which can be determined using magnetic field viewing film or equivalent.

8.24.3 Calculation—The flux index ($\text{kG}^2 \text{mm}^2$) is calculated by multiplying the area of the pole surface (mm^2) of the magnet by the square of the maximum flux density (kG^2).

8.24.4 Magnet Use and Abuse Testing—Each unique component shall be tested per this section. A new toy shall be used that has not been subjected to other use and abuse testing. All the testing in this section must be performed in series on each

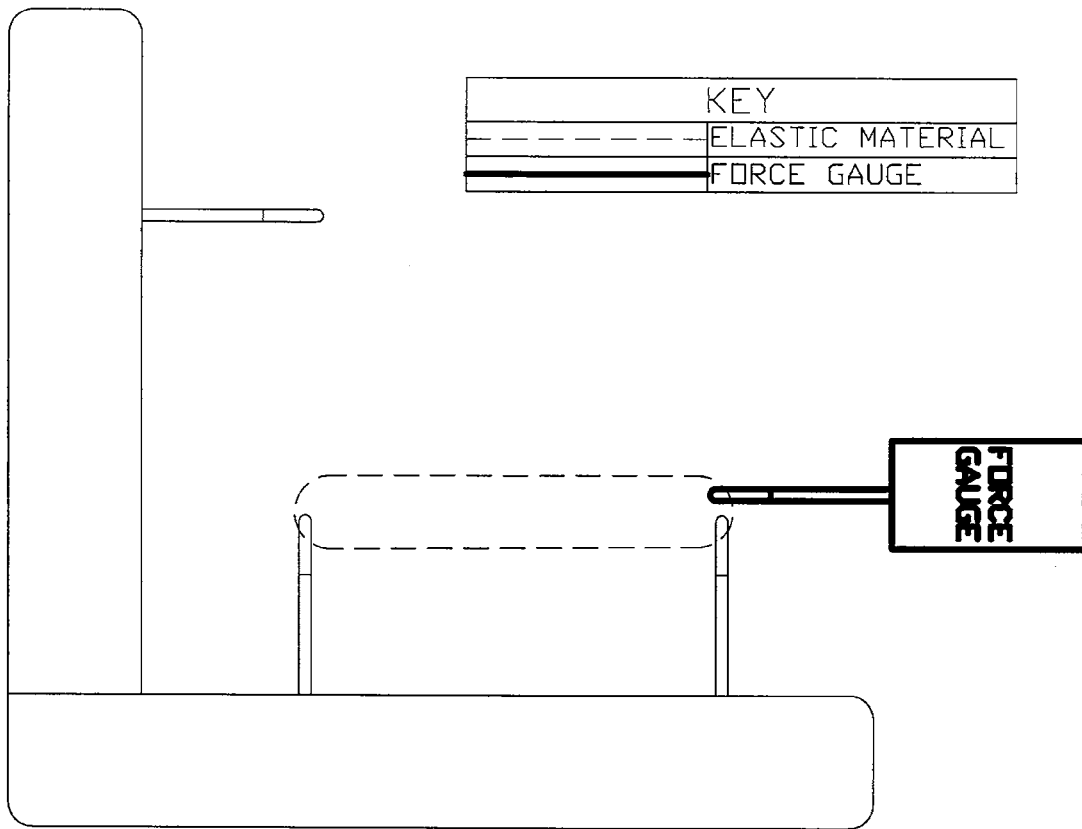

FRONT VIEW

FIG. 36 (b) Test Procedure for Cords and Loops, Step 2 (continued)

unique component (that is, testing must follow 8.24.4.1-8.24.4.5 in sequential order).

8.24.4.1 *Cycling as Received*—One thousand (1000) cycles of intended use shall be performed on the as-received magnetic parts or magnetic assemblies. The magnetic parts shall be brought together to a distance that initiates magnetic attraction, released, and then pulled apart to the distance where magnetic attraction ceases. Each attachment and detachment shall count as 1 cycle. If no other magnets or magnetic parts are provided with the toy, then the mating metal part or surface, according to the toy’s intended play pattern, should be used for cycling purposes. The testing may be automated or performed manually.

8.24.4.2 *Impact Test*—Place the magnetic part or magnetic component in an orientation that is most likely to result in breakage on a plane horizontal steel surface and drop a metallic weight with a mass of 2.2 lb (1.0 kg) distributed over an area with a diameter of 3.1 in. (78.7 mm) through a distance of 4.0 in. (101.6 mm) on to it. Determine if a hazardous magnet or a hazardous magnetic component is generated.

8.24.4.3 *Torque Test*—Test according to 8.8.

8.24.4.4 *Tension Test*—Test according to 8.9.

8.24.4.5 *Cycling – After Abuse Test*—Repeat the testing described in 8.24.4.1.

8.25 *Test Methods for Locking Mechanisms or Other Means:*

8.25.1 *Locking Mechanisms or Other Means:*

8.25.1.1 Erect the product in accordance with the manufacturer’s instructions.

8.25.1.2 Secure the product so that the normal folding motion is not impeded.

8.25.1.3 Apply a force of 45 lbf (200 N) to the product, but not to the mechanism itself, in the direction normally associated with folding. Apply the force gradually over a 5 s period and maintain for an additional 10 s before releasing the force.

8.25.1.4 Perform this procedure five times within a 2 min period.

8.25.2 *Locking Test Method*—With the product in the manufacturer’s recommended use position, gradually apply a force of 10 lbf (45 N) to the locking mechanism in the direction tending to unlock it. The locking mechanism shall not unlock until a minimum force of 10 lbf (45 N) has been achieved.

8.26 *Test for Overload of Ride-On Toys and Toy Seats:*

8.26.1 Place the toy on a horizontal plane.

8.26.2 The test load(s) shall be three times the weight indicated in Table 6 at the highest age of the age range for which the toy is intended. The test for overload requirements shall be conducted so that it will be consistent with the

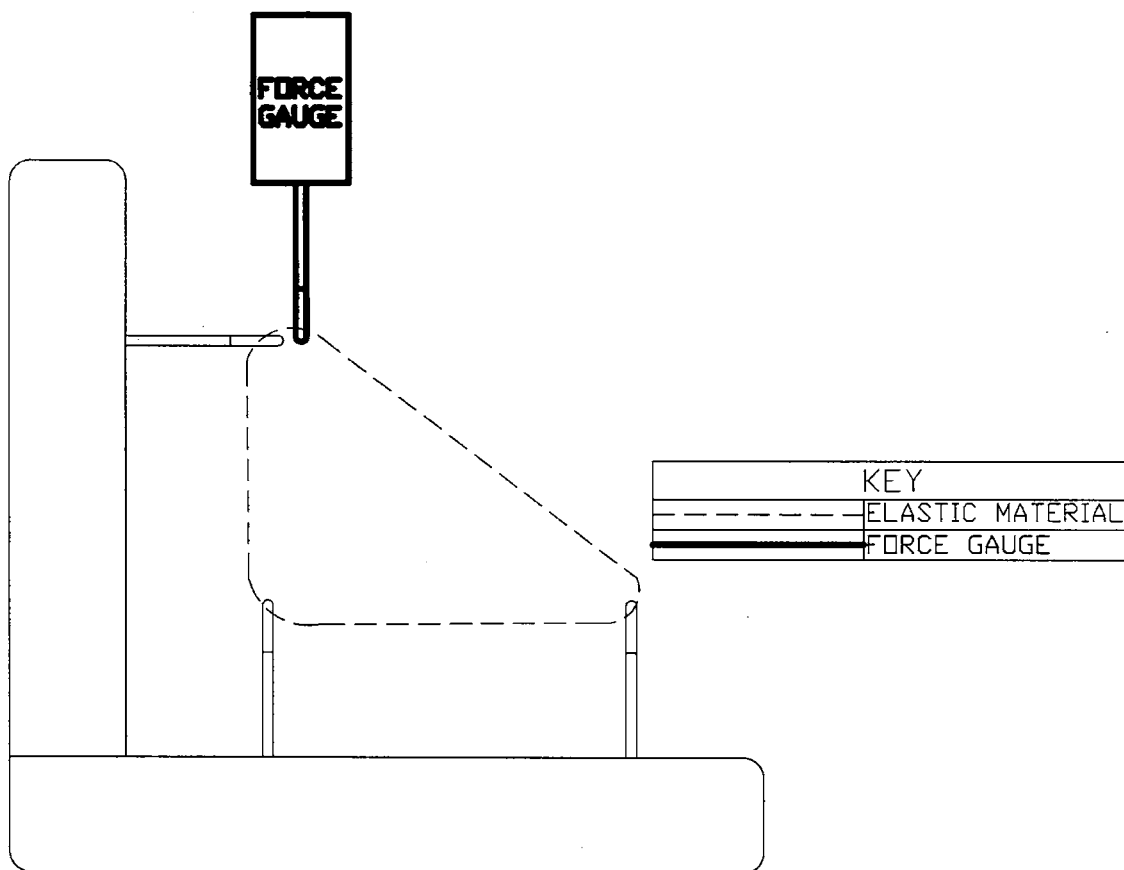

FRONT VIEW

FIG. 36 (c) Test Procedure for Cords and Loops, Step 3 (continued)

advertised weight capacity if that figure is higher than the minimum weight capacity in accordance with Table 6. When the highest age of the intended age range falls between two ages listed in Table 6, the higher of the two shall be chosen.

8.26.3 Where the toy is intended to bear the weight of more than one child at a time, test each sitting or standing area (3× the weight tested separately in each location).

8.26.4 Apply a static load(s) that is equal to the weight as determined by the criteria above. The load(s) shall be applied so that it is as close as possible to the geometric center of the designated seating or standing area(s). If there is no designated seating or standing area(s), the load shall be placed at the least favorable position that it is reasonable to anticipate that the child will choose to sit or stand.

8.26.5 Observe whether the toy collapses within 1 min after application of the static load(s).

9. Identification

9.1 So that purchasers may identify products conforming to all of the requirements of this specification on toy safety, producers, importers, and distributors may include a statement of compliance in conjunction with their name and address on product labels, invoices, and sales literature.

9.1.1 The following statements are suggested:

(1) Conforms to the requirements of ASTM Standard Consumer Safety Specification on Toy Safety, F963 (name and address of producer, importer, or distributor).

(2) Conforms to the safety requirements of Specification F963 (name and address of producer, importer, or distributor).

10. Keywords

battery-operated toys; children; safety labeling; safety testing; toy safety requirements

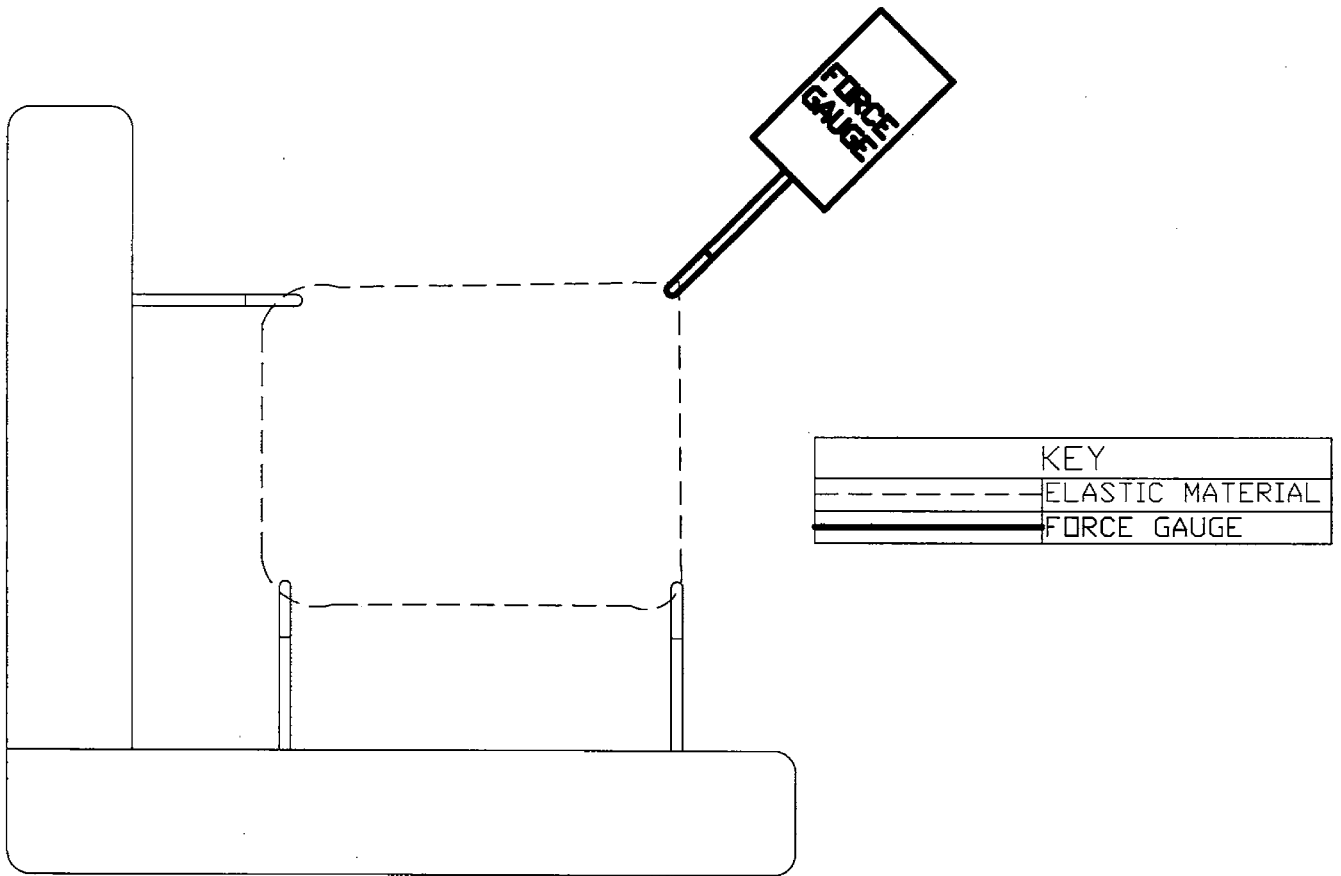

FRONT VIEW

FIG. 36 (d) Test Procedure for Cords and Loops, Step 4 (continued)

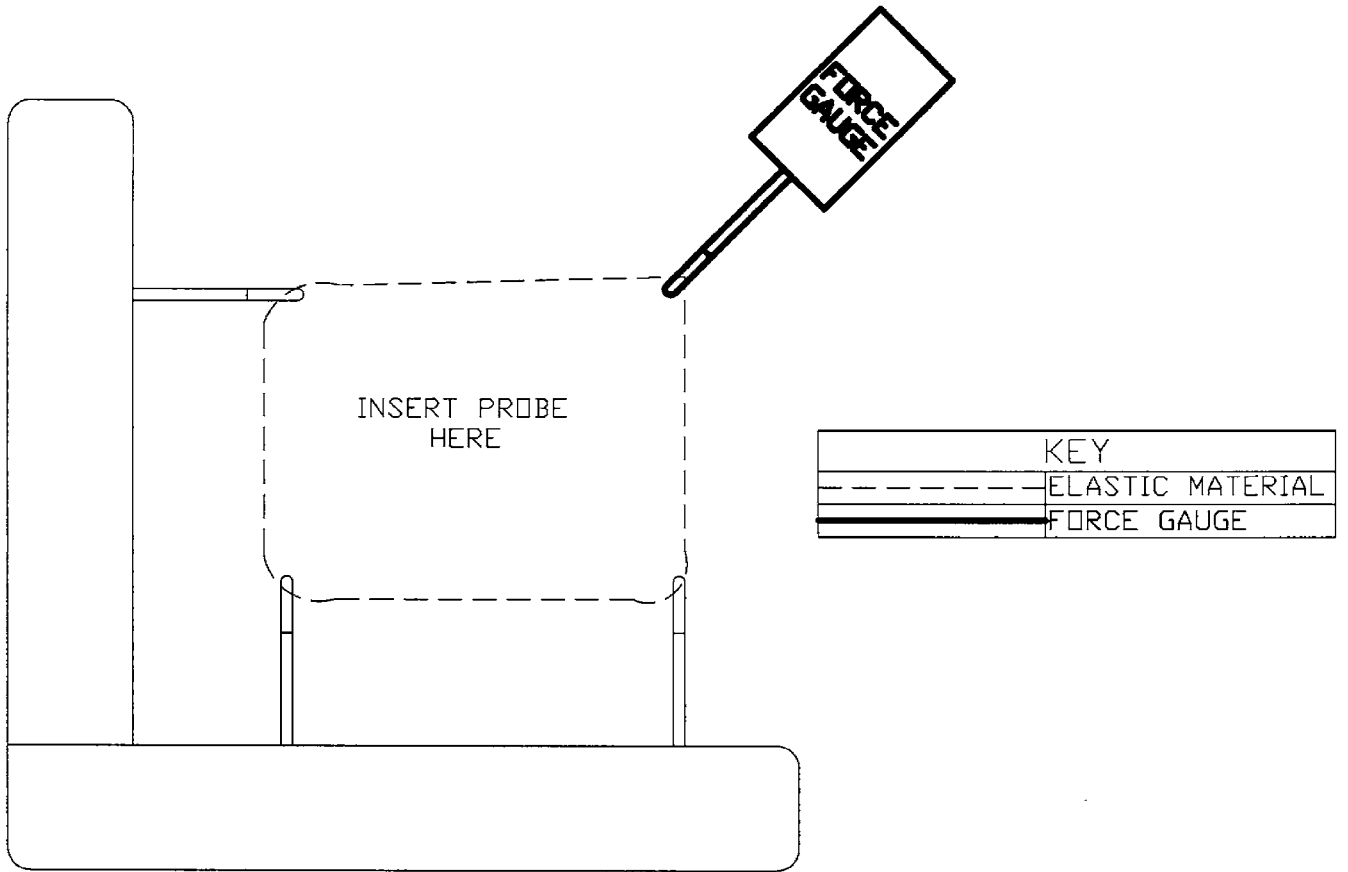

FRONT VIEW

FIG. 36 (e) Test Procedure for Cords and Loops, Step 5 (continued)



FIG. 37 Example of Typical Test Set-Up

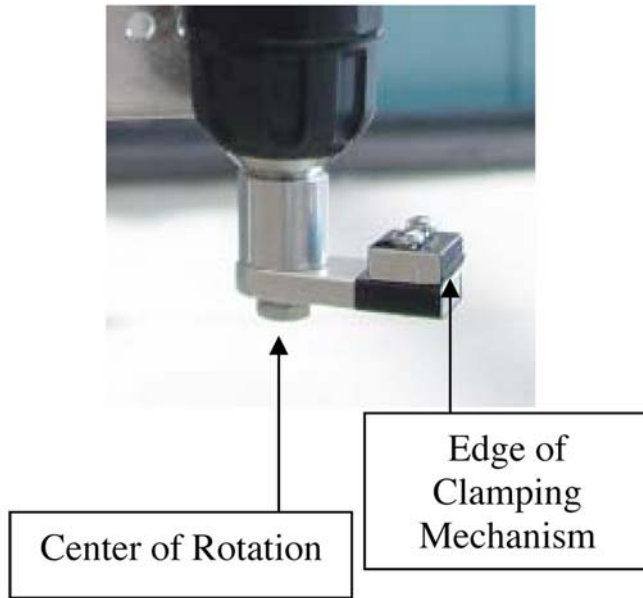

FIG. 38 Close-Up of Clamp

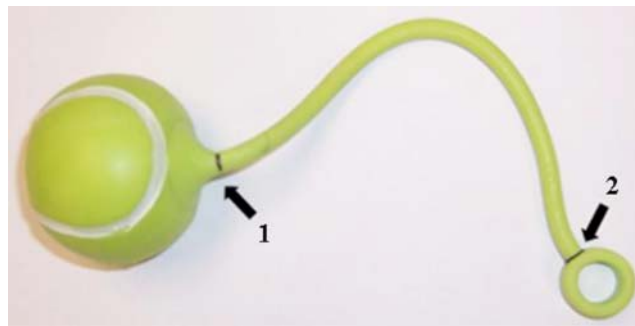

FIG. 39 Marking Unloaded Tether

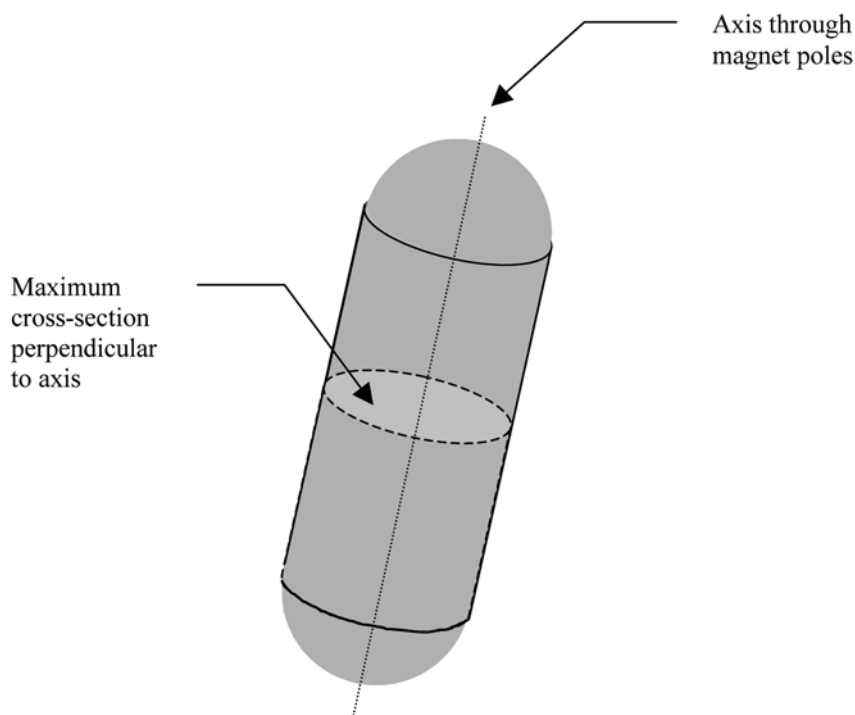

FIG. 40 Illustration of Pole Surface on a Magnet with Rounded Ends

ANNEXES

(Mandatory Information)

A1. AGE GRADING GUIDELINES +

A1.1 Purpose and Scope

A1.1.1 Good age-grading practices are important to ensure that a toy is appropriate and safe at particular stages of physical and mental development.

A1.1.2 Age labeling is intended to provide point-of-sale guidance to consumers for the selection of appropriate toys for children with respect to average abilities, interests of various age groups, and safety aspects of the toys themselves.

A1.1.3 This guideline is intended to provide thoughts and considerations necessary to establish meaningful age recommendations for toy products.

A1.1.4 “Guidelines for Relating Children’s Ages to Toy Characteristics (1985)” is available from the Consumer Product Safety Commission, Washington, DC 20207.

A1.2 Criteria for Establishing Age Grades

A1.2.1 The following criteria should be considered when establishing age grading for a toy. While all of these should be considered in total, each one may be weighted individually to arrive at the appropriate age grading.

A1.2.1.1 The physical ability of a child to manipulate and play with the specific features of a toy. This necessitates an understanding of the physical coordination, fine and gross motor capabilities, size, and strength generally available at a given age.

A1.2.1.2 The mental ability of a child to understand how to use the toy (that is, understand instructions, sequences of operations, objective of the toy). Consideration of the mental skills at a given age is important in order to provide a concept that will challenge abilities and stimulate further development, yet not frustrate. Accomplishment should be neither too easy nor too difficult to be satisfying to the child.

A1.2.1.3 The toy must meet play needs and interests at different levels of development. Understanding developmental levels and identifying play materials and play environments to enhance each developmental stage is important for assigning appropriate age grades. Play interests and toy preferences change rapidly; there should be careful attention to a child’s preference or aversion to specific toy subjects at certain stages. In order for a toy to enhance play, it obviously must be appealing to its user. In short, it must be fun.

A1.3 Tools

A1.3.1 Use of the following tools can help guide the establishment of meaningful age grading for a toy. These tools are not arranged in a particular order of importance; all of them should be considered during the age grading process.

A1.3.1.1 Prior experience with the toy or a similar toy in the marketplace indicating suitability for a specific age group.

A1.3.1.2 Reference materials on comparative body measurements and human factors elements.

A1.3.1.3 Reference resources on child development norms to establish developmental mileposts.

A1.3.1.4 Identification of developmental features to be enhanced/stimulated within certain age spans.

A1.3.1.5 Expertise of outside consultants, child development specialists, physicians, and psychologists.

A1.3.1.6 Testing of models or prototypes with children.

A1.3.1.7 Observing skill levels in children at play.

A1.3.1.8 Seeking opinions of parents.

A1.3.1.9 Interacting with children and asking questions.

A1.4 Safety Considerations of Age Grading

A1.4.1 The toy must be safe for the intended user. Once the skill level has been determined, the design must be tailored to satisfy the requirements of this specification associated with that age level.

A1.4.2 Age grades are indicators of average development, which does not necessarily reflect suitability for the exceptional child. A parent remains the best judge of whether the child is at the appropriate development stage for safe play with a particular toy.

A1.4.3 A primary consideration should be potential choking and aspiration hazards associated with small parts. Children under the age of three are more prone to placing objects in their mouths. However, the propensity to put nonfood objects in the mouth does not disappear at the chronological age of three years. The following toys are appropriate for children under three years of age and are cited specifically as subject to the safety requirements of **16 CFR 1501** for small parts regulations:

A1.4.3.1 Squeeze toys, teethers, crib exercisers, crib gyms, crib mobiles, toys intended to be affixed to a crib, stroller, playpen, or baby carriage, pull and push toys, pounding toys, blocks and stacking sets, bathtub, wading pool and sand toys, rocking, spring, and stick horses and other figures, chime and musical balls and carousels, jack-in-the-boxes, stuffed, plush, and flocked animals and other figures, and those preschool toys, games and puzzles, riding toys, dolls and animal figures, cars, trucks, and other vehicles that are intended for use by children under the age of three years.

A1.4.4 Some of the characteristics of toys that describe those preschool toys that are appropriate for children under the age of three years are listed below by class of toy:

A1.4.4.1 *Dolls*—Soft-bodied baby dolls or character dolls that are for holding or cuddling, stuffed or “bean bag” dolls, rag or cloth dolls with simple features (including accessories), and lightweight plastic dolls with simple features and limited articulation at the limb joints.

A1.4.4.2 *Infant Toys*—Toys intended to be used in a crib or playpen, to be held easily by small hands, shaken, grasped, rattled, or cuddled.

A1.4.4.3 *Toy Vehicles*—Cars, trucks, boats, and trains of simple chunky shape, decorated in primary colors without extensive descriptive detail or representation of a particular make or model of vehicle and that require simple actions such as rolling, dumping, pushing, and releasing.

A1.4.4.4 *Action Toys*—Simple action toys for the identification of sounds or pictures and surprise action toys.

A1.4.4.5 *Early Learning Toys*—Toys, books, and puzzles for learning basics such as letters or numbers or shapes, and simple physical motions such as turning wheels or knobs, pulling and letting go, or sorting by size, etc.

A1.4.4.6 *Blocks and Stacking Toys*—Toys that do not require finger dexterity or fitting together of small intricate pieces.

A1.4.4.7 *Soft Balls and Similar Items*—Soft, lightweight balls or other shapes for squeezing, shaking, rolling, or tossing.

A1.4.5 Toys that should not be considered appropriate for very young children, and therefore not be age labeled as such, have the following characteristics:

A1.4.5.1 Toys that require intricate finger movements or controlled adjustments, fitting intricate pieces together.

A1.4.5.2 Toys, for example, games that require or incorporate elements of reading ability beyond the ABCs or 123s.

A1.4.5.3 Toys that simulate adult figures or characters and their associated accessories.

A1.4.5.4 Collecting sets (for example, figures and vehicles).

A1.4.5.5 Projectile-type toys, launched vehicles, planes, etc.

A1.4.5.6 Makeup sets.

A1.4.6 Another major development cutoff has been cited at approximately eight years of age, at which time reading ability has progressed so that a child can, on his own, read, understand, and heed instructions, caution statements, etc. Because the instructions and caution statements are necessary for the safe use of the product in some cases, those products should be labeled for use by children over the age of eight. Products that fall into this category include the following:

A1.4.6.1 Science and environmental kits or sets containing breakable glass components and complex instructions.

A1.4.6.2 Complex model and craft sets requiring precision assembly and finger dexterity or incorporating sharp tools or components.

A1.4.6.3 Electrically operated toys incorporating heating elements.

A1.4.6.4 Certain chemistry sets, fueled model vehicles, and rockets, etc. that contain chemicals that may be hazardous, cannot generally be handled safely by children unable to read and understand instructions and cautionary statements. The minimum age for which any such product should be recommended is eight years and then *only* with adult supervision.

A1.5 Descriptive Age Labeling

A1.5.1 Manufacturers can assist parents and other purchasers in the appropriate selection of toys by incorporating descriptive labeling to identify potential safety concerns if the toy is accessible to children outside the recommended age group.

A1.5.2 For example, if a toy contains small play pieces and is labeled for older children, such as an action figure set, the manufacturer should consider including a statement on the retail packaging that the toy contains small pieces.

A1.5.3 Factors to consider would include the appeal of the toy to young children, market experience, the design or construction of the toy, and whether the packaging provides visual indication of any small play pieces. In addition, a

manufacturer should consider the probability that a purchaser may overestimate a child's physical or mental abilities and the child's understanding of a potential hazard related to the toy.

A2. PACKAGING AND SHIPPING

A2.1 Packaging

A2.1.1 Packages that are intended to be opened by adult purchasers should be constructed as to avoid hazards during the opening process from metal fasteners, particularly staples, and should not contain common pins used to position the toy within the package.

A2.2 Shipping

A2.2.1 Packaged and unpackaged toys can be subjected to a wide variety of tests designed to test the ability of toys to

withstand the destructive forces encountered in the distribution cycle. The tests used most widely include drop, vibration, compression, and incline impact. Limited testing may be sufficient for many toys, especially those that are of light weight and constructed of resilient materials, such as dolls and stuffed toys. Others, however, such as large plastic or heavy metal toys, may be damaged during shipment and should be subjected to appropriate tests. Guidance for useful tests can be obtained from the following ASTM sources: Test Methods [D642](#), [D5276](#), [D880](#), and [D999](#).

A3. DESIGN GUIDELINES FOR TOYS ATTACHED TO CRIBS OR PLAYPENS

A3.1 Purpose and Scope

A3.1.1 This annex provides guidance for design practices intended to encourage the careful examination of product characteristics and configurations with respect to safety. As there are no objective means for determining conformance with these design guidelines, they are not to be used to judge compliance with this specification.

A3.2 Guidelines

A3.2.1 Designs for all products intended to be attached to cribs or playpens should be accomplished in a manner that minimizes the potential for strings, ribbons, elastic, or parts of clothing to become caught on the product, such that an infant

is placed in a dangerous predicament in which possible strangulation could occur.

A3.2.2 Examples of the implementation of good design practices for crib and playpen environments include the following:

- (1) Rounded corners with the use of generous radii wherever possible.
- (2) Smooth contours that minimize abrupt changes in shape that could easily become a catch point for strings, ribbons, elastic, or loose clothing.
- (3) Isolation of fastening hardware using recesses, counterbores, or other similar methods.
- (4) Reduction of the potential for any mismatch of surfaces where a catch point could develop.

A4. DESIGN GUIDELINES FOR BATH TOY PROJECTIONS

A4.1 Purpose and Scope

A4.1.1 This annex provides guidance for design practices intended to result in bath toy projection characteristics and configurations that will minimize the risk of injury to the genital and anorectal area if a child were to sit or fall onto the bath toy projection while in an unclothed or minimally clothed state. Some examples of these potentially hazardous projections include but are not limited to rigid fins of fish, rigid hulls, funnels, and masts of boats.

A4.2 Guidelines

A4.2.1 It is important that the design of a bath toy be developed with consideration of the shapes, dimensions and materials of any projections on the toy such that penetration and impalement hazards are minimized.

A4.2.2 Examples of good design practices include:

A4.2.2.1 *Non-Vertical Projections*—It is preferable to have projections designed such that they are always non-vertical

when the toy is evaluated in all stable positions including consideration of the potential positions the toy can rest on the bottom of a bath tub, with or without water present in the bath tub, to produce a vertical or nearly vertical projection.

A4.2.2.2 *Stability*—If a toy topples over when force is applied to the end of the vertical projection, both when the bath toy is empty and filled with water, then the vertical projection is unlikely to be hazardous.

A4.2.2.3 *Accessibility*—Vertical projections can be protected by suitable means to minimize possible injury. A protected projection is one that has adequate adjacent structure (ribs, housings, or other permanent components) to render the projection unlikely to cause penetration or impalement hazards.

A4.2.2.4 *Flexibility*—Vertical projections can be designed to be flexible to minimize possible injury. This can be done through the choice of materials, a design which bends or compresses or the dimensions of the projection.

A4.2.2.5 *Diameter*—The diameter (or cross-sectional projected area) of a vertical projection can be sized large enough to minimize possible injury.

A5. FLAMMABILITY TESTING PROCEDURE FOR SOLIDS AND SOFT TOYS

A5.1 Purpose

A5.1.1 This annex establishes the protocol and general criteria for flammability testing of solids, and soft toys in conformance with the requirements of 16 CFR 1500.3(c)(6)(vi).

A5.2 Definitions

A5.2.1 *major axis*—a straight line through the longest dimension of the product connecting the most distant parts or ends of the product. A product can have more than one major axis (see Fig. A5.1), but they must be equal in length. For toys that pose or transform, position the product so that its major axis is the longest possible dimension.

A5.2.2 *soft toy*—any stuffed or plush toy, that may or may not be parts or components of other toys.

A5.2.3 *solids*—toys or toy parts constructed of rigid, flexible, or pliable solids.

A5.2.4 *accessories*—an item intended to be removed to enhance the play pattern.

A5.2.5 *strings*—long slender flexible material usually consisting of several strands (as of thread or yarn) woven or

twisted together, usually used to bind, fasten, tether, or tie. This does not include string when used, for example, for hair on a doll.

A5.2.6 *paper*—a thin, flat, single layer of material produced by the compression of fibers. The fibers are usually composed of cellulose. Examples of paper products are traditional playing cards, newspaper, magazines, and construction paper. Examples of products that are not paper are cardboard, and paperboard (multiple layers of paper bonded together).

A5.3 Exemptions

A5.3.1 Strings, paper, and ping-pong balls.

A5.3.2 Accessible components having a major dimension of 1 in. (25 mm) or less.

A5.3.3 Textile fabrics intended to be removed shall be tested separately and meet the requirements of A6.1. Fabrics not intended to be removed shall become subject to the test to the extent that it becomes a part of the test surface.

A5.3.4 Sleeping bags.

A5.3.5 Packaging materials intended to be discarded by the consumer. Components of packaging that are likely to be incorporated into the play pattern of the toy are not exempt.

A5.4 Sample Preparation for Solids and Soft Toys

A5.4.1 Test product completely assembled as per manufacturer’s instructions. If disassembly is required for storage purposes only, test when fully assembled as per manufacturer’s instructions. If assembly or disassembly, or both, is part of the play pattern (that is, accessories, puzzles, construction toys, etc.) test each component separately.

A5.4.2 Remove all string or paper from the product as deemed necessary.

A5.5 Procedure for Solids and Soft Toys

A5.5.1 Place the prepared sample in a draft-free area that can be ventilated and cleared after each test. The temperature of the sample at the time of testing shall be between 68 and 86°F (20 and 30°C) at a relative humidity of 20 to 70 %.

A5.5.2 The test fixture shall be corrected to a clean condition prior to the start of each test.

A5.5.3 Measure the dimensions of the sample, and support it by means of the test fixture (see Fig. A5.2) or equivalent, so that the ends of the major axis are oriented horizontally. Placing a scale along the major axis is a sufficient means for gauging the burn distance.

A5.5.3.1 *Orientation and Locations for Ignition of Specimens*—When orienting specimens, provide support over the entire length of the major axis without sagging, making sure the supporting device does not retard the spread of flame materially. Optional: for samples with long hair, it may be necessary to add fine wire (24 AWG or higher) between some

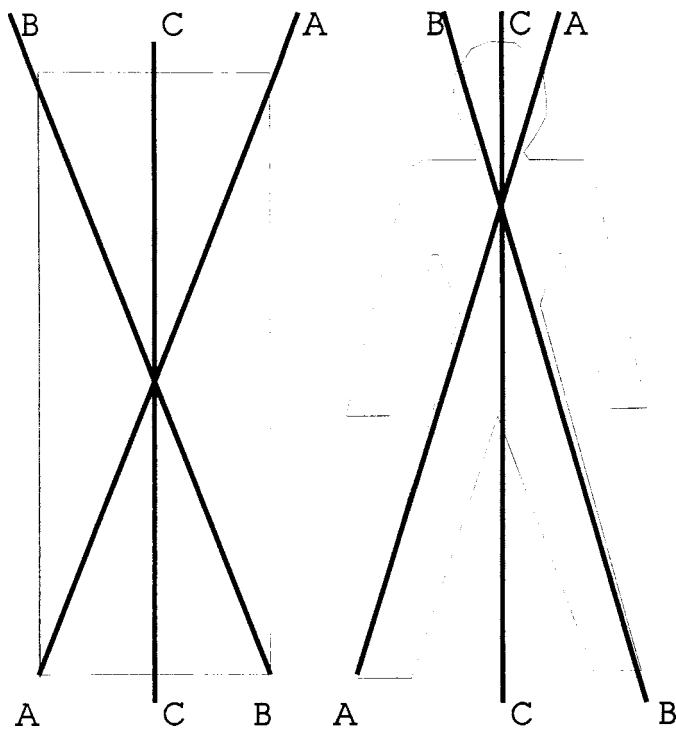

NOTE—Lines A-A and B-B are both major axes. Line C-C is not a major axis.

FIG. A5.1 Illustration for Determining Major Axis

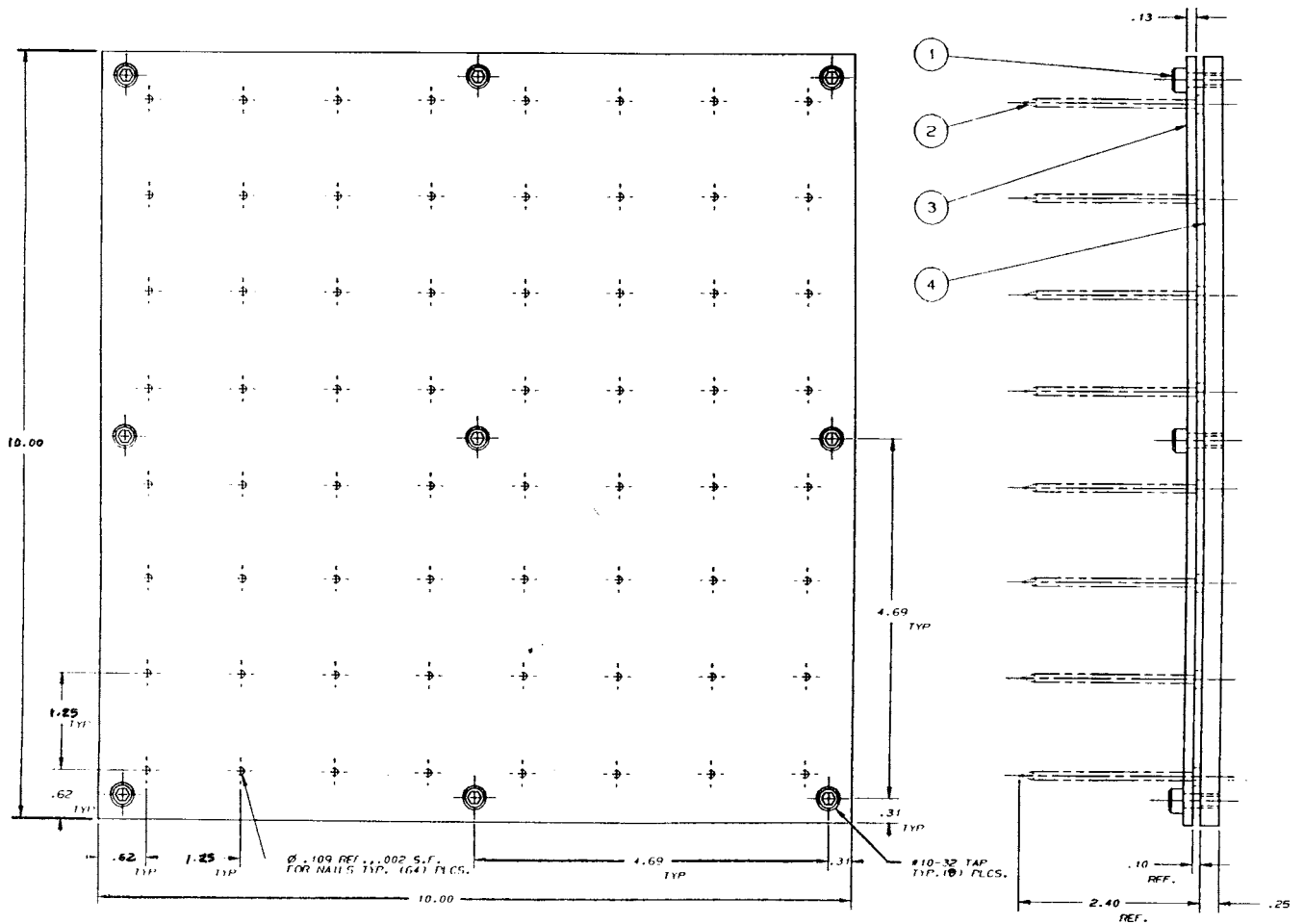

Item	Required	Description	Material
1	9	# 10-32 × 0.38 LG.	S.H.C.S.
2	64	# 8d × 2.50 LG.	Common Nail
3	1	0.13 × 10.00 × 10.00 LG.	Stainless Steel
4	1	0.25 × 10.00 × 10.00 LG.	Stainless Steel

NOTE 1—Tolerances (unless otherwise specified):

- 3 Place DIMS ± 0.005
- 2 Place DIMS ± 0.015
- Angles ± 1°

NOTE 2—Break all sharp edges and screw to suit unless otherwise specified.

FIG. A5.2 Suggested Flammability Test Fixture

nails to provide sufficient support for the hair. The addition of support for hair is not necessary unless the hair hangs down vertically while lying on the test fixture.

NOTE A5.1—The CPSC does not test hair separately but rather tests hair as a normal part of the toy. The toy might be tested in a face-down position, with the hair in a horizontal position on top of the toy. The toy could also be tested lying on its back, with the hair lying beneath the toy. Hair that hangs vertically would not be used to calculate the burn rate.

(1) A sample that is so large that it becomes impractical to support its entire length must be arranged in such a manner that support at the end of a major axis is provided by the test fixture.

(2) One or more specimens shall be ignited at one end of the major axis, and when practical, one or more specimens shall be ignited at the opposite end of the major axis.

Specimens shall be positioned in the worst case position, as dictated by experience.

A5.5.4 Trim the candle and wick as necessary to maintain a flame height of 5/8 to 1 in. (16 to 25 mm).

A5.5.4.1 Hold a burning paraffin candle whose diameter is at least 1 in. (25 mm) so that the flame is a minimum of 5/8 in. (16 mm) high, with the tip of the inner cone of the flame in contact with the surface of the sample at the end of the major axis for 5 s. Maintain contact of the candle with the sample for 5 s or until ignition occurs. If the sample melts away from the flame, move the candle and maintain contact for the full 5 s or until the sample ignites. If the ignition occurs immediately, hold the candle steady and allow the ignited flame to move away.

A5.5.5 Remove the candle and allow the sample to burn for an additional 55 s (total burn time including ignition time is 60 s) or until the flames reach the opposite end of the major axis. Determine the time of combustion by means of a stop watch. Do not allow the total test time to exceed 60 s with a self-sustaining flame.

A5.5.6 Extinguish the flame with a CO₂ or similar nondestructive extinguisher, if necessary, after the 60 s. The experienced application of water is an acceptable method for extinguishing the flame.

NOTE A5.2—Extinguishing the flame must be accomplished in a manner that preserves the accuracy of the burned distance.

A5.5.7 Measure the length of the burned area, and calculate the rate of burning along the major axis of the sample.

A5.5.8 Products that do not ignite are considered acceptable. No burn rate is calculated for these samples. The burn rate for products that self-extinguish in less than 60 s shall be computed by using the actual burning time as the denominator when calculating the burn rate. For example, ignited product burns 3 in. (76 mm) in 20 s and self-extinguishes. The burn rate is calculated as follows:

$$\frac{3 \text{ in.}}{20 \text{ s}} = 0.15 \text{ in./s} \quad (\text{A5.1})$$

A5.5.8.1 Burn-rate calculations for a product that self-extinguishes must be approached cautiously to avoid the introduction of measurement error since small measurement errors can become a significant portion of final calculations when the burn distance is short.

NOTE A5.3—It is unlikely that the CPSC would pursue an enforcement action that includes a burn rate calculation higher than 0.10 in. per second and yet consistently self-extinguishes during the test. However, the CPSC reserves the right to proceed with an action if such a burn rate may result in the product's causing substantial personal injury or substantial illness.

(1) When the product does not self-extinguish, the flame shall be allowed to continue for a total time of 60 s. Calculate the rate of burning using the actual distance of flame spread during the full 60 s. For example, the product ignites and burns 9 in. (229 mm) in 60 s. The burn rate is calculated as follows:

$$\frac{9 \text{ in.}}{60 \text{ s}} = 0.15 \text{ in./s (a flammable solid)} \quad (\text{A5.2})$$

NOTE A5.4—While testing, samples shall not be extinguished prematurely if such action will affect the burn rate. For example, if a stuffed rabbit is ignited at the tip of one ear and the flame is extinguished when the flame reaches the base of the ear, this may produce an inflated burn rate if the ear material burns at a faster rate than the rest of the product. Therefore, allow the sample to burn the full 60 s taking into account both the ear and the rest of the product.

(2) There may be scenarios where the flame may need to be extinguished prematurely prior to reaching the full 60 s. For example, the major axis of a product is 6 in. in length. The product ignites and burns the total length of the major axis (6 in.) in 40 s but continues to flame. Once the flame travels the full length of the major axis, extinguish the flame immediately regardless of whether or not the full 60 s has been reached. The burn rate is calculated as follows:

$$\frac{6 \text{ in.}}{40 \text{ s}} = 0.15 \text{ in./s} \quad (\text{A5.3})$$

A5.6 Requirements

A5.6.1 A toy shall be considered a flammable solid if it ignites and burns with a self-sustaining flame at a rate greater than 0.1 in./s (2.5 mm/s) along its major axis.

A5.6.2 If the burn rate of a composite product (that is, solid/fabric combined) exceeds 0.10 in./s in part due to the presence of a permanently attached fabric, then a secondary test shall be performed to determine compliance. The secondary test shall consist of removing the permanently attached fabric from the solid and retesting the solid component separately. When sold as part of a toy such that the permanently attached fabric cannot be removed without causing damage to the toy and the fabric (that is, fabric covered book, stuffed dolls/animals, etc.) or if the toy is an enclosure that a child can enter, the fabric shall become subject to the solids test to the extent that it becomes a part of the major axis.

NOTE A5.5—The permanently attached fabric that was removed from the sample must now be subject to meeting the requirements of Annex A6.

A5.6.3 Criteria for Acceptance:

A5.6.3.1 Sample size = four, whenever practical.

A5.6.3.2 A burn rate is not calculated for samples that do not ignite.

A5.6.3.3 Calculate the burn rate to two significant figures (to the nearest hundredth using conventional rounding rules, that is, for 5 or higher, round up).

A5.6.3.4 Round the burn rate to the nearest tenth (that is, round 0.15 up to 0.2).

A5.6.3.5 Level of acceptance = 0.1 in./s (2.5 mm/s), maximum, along the major axis.

A5.6.3.6 *Additional Guidance for Manufacturers*—Manufacturers' decisions on the performance of an item should be based on a minimum of four samples. This provides a reasonable opportunity for detecting undesirable variations in the product. Proceed as follows:

(1) If the burn rate of all samples is less than 0.1 in./s (2.5 mm/s), accept.

(2) If the burn rate of all samples is greater than 0.1 in./s (2.5 mm/s) but less than 0.15 in./s (3.75 mm/s), accept and consider further investigation for action to improve performance.

(3) If the burn rate of one of the samples is 0.15 in./s (3.75 mm/s) or greater, reject and repeat the test with four additional samples (one time only). If the burn rate of any of the retested samples is 0.15 in./s. or greater, reject.

(4) If the burn rate of more than one of the initial 4 samples is 0.15 in./s (3.75 mm/s) or greater, reject.

NOTE A5.6—CPSC makes its decision on whether a product is a flammable solid based on the burn rate of each individual sample. It then determines whether the product may cause substantial personal injury or substantial illness during or as a proximate result of any customary or reasonably foreseeable handling or use. CPSC has no objection to other laboratories rounding off to the nearest 0.1 in./s. It will calculate burn rates to two decimal places but does not envision enforcement action where the burn rate is greater than 0.10 in./s and less than 0.15 in./s. However, CPSC reserves the right to proceed if such burn rate may result in the product's causing substantial personal injury or substantial illness.

A6. FLAMMABILITY TESTING PROCEDURE FOR FABRICS

A6.1 Purpose

A6.1.1 This annex establishes the protocol and general criteria for flammability testing of fabrics in conformance with the requirements of **16 CFR 1500.3** (c)(6)(vi).

A6.2 Definitions

A6.2.1 *fabric*—any coated or uncoated material (except film and fabrics having a nitro-cellulose fiber, finish or coating) that is woven, knitted, felted, or otherwise produced from any natural or manmade fiber, or substitute therefore, or combination thereof.

A6.2.2 *plain surface fabric*—any textile fabric which does not have an intentionally raised fiber or yarn surface such as pile, nap, or tuft, but shall include those fabrics having fancy woven, knitted or flock printed surfaces.

A6.2.3 *raised surface fabric*—any textile fabric which has an intentionally raised fiber or yarn surface such as a pile, nap or tufting.

A6.3 Exemptions

A6.3.1 Fabrics where a contiguous 2 by 6 in. piece cannot be extracted.

NOTE A6.1—If a contiguous 2 by 6 in. piece of fabric cannot be obtained, but due to the existence of other fabrics adjacent to it a composite 2 by 6 in. sample can be obtained, and the fabrics in question are permanently attached to a common substrate, then it shall be tested. An example of this would be a doll's hula skirt made of thin strips of fabric 6 in. in length. Each individual strip is joined at the top by a common substrate (that is, plastic waistband) and when combined with the other strips immediately adjacent to it, a 2 by 6 in. sample can be extracted.

A6.3.2 Fabrics that are permanently attached to a solid must initially be tested with the solid per **Annex A5**.

A6.4 Sample Preparation

A6.4.1 Precondition all fabrics in a horizontal position for a minimum of 30 min at a temperature of $221 \pm 10^\circ\text{F}$.

A6.4.2 Fabrics intended to be washed shall be subjected to AATCC Home Laundering Fabrics Prior to Flammability Testing to Differentiate Between Durable and Non-Durable Finishes - 2007.

A6.4.3 A total of 5 samples, whenever practical, shall be cut for each location. Samples may be obtained from more than one toy.

A6.4.4 Samples shall be tested in the manner in which they appear on the toy (that is, exposed side face-up).

A6.4.5 Use the most onerous orientation (for example, warp or fill).

A6.4.6 If it is necessary to use a sample that consists of more than one type of fabric, then take the sample from the most onerous location.

A6.4.7 If fabric is layered and the layers are permanently secured to one another (for example, stitched together) at any point, cut through as many materials necessary to obtain the sample and include all layers in a single sample. Orient layers in the sample holder in the same manner they appear on the toy. (See **Fig. A6.1**.)

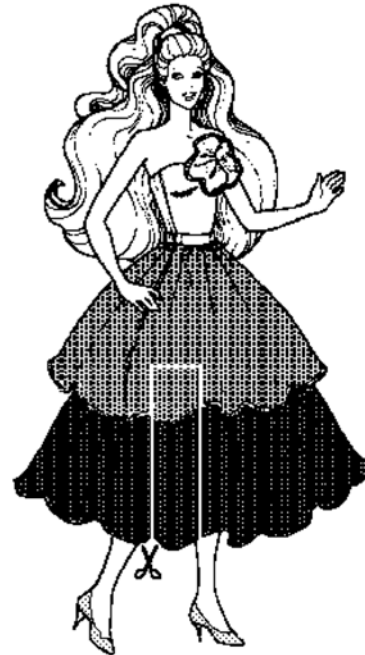

FIG. A6.1 Layered Fabric Sample

A6.4.8 For fabrics with finished ends made of a different material (that is, lace, ribbons, etc.) test the finished ends separately.

A6.4.9 If the finished ends consist of the same material as the sample being tested (that is, hemmed, folded, etc.) then attempt to exclude this from the 2 by 6 sample. In addition, if the fabric contains any seams or stitching, attempt to exclude them from the sample. If a sample cannot be extracted by excluding the finished ends or seams/stitching, then include them in the sample during testing, however, orient the sample in the fixture so that the finished ends or seams/stitching are at the top or side of the fixture to minimize any effect it may have on the burn rate.

A6.4.10 If the fabric requires support in order to be held in the fixture, then the use of thin gauge wire (24 AWG or higher) strung across the plate opening at equidistant points from each other is acceptable. (See **Fig. A6.2**.)

A6.4.11 Regardless of sample size, if the fabric has non-fabric components permanently attached to it (that is, buttons, sequins, beads, etc.) remove these components only if removal will not cause permanent damage to the fabric or to the non-fabric component. Then test each component separately as applicable. If permanent damage cannot be avoided during removal, then test with non-fabric components attached.

A6.5 Test Procedure

A6.5.1 Test fabrics per the test method specified in **16 CFR 1610.4(g)**.

A6.5.2 Use the equipment as specified in **16 CFR 1610.4(b)**.

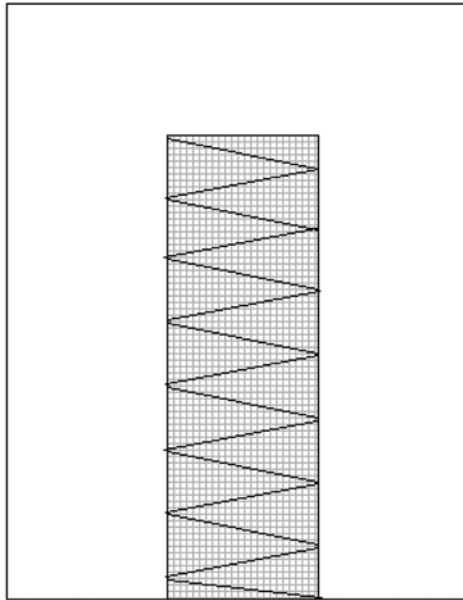

FIG. A6.2 Fabric Requiring Support

A6.6.1.3 If only 1 of 5 specimens ignites and burns the stop cord in less than 3.5 seconds, test another set of 5 specimens. Compute the average time of flame spread for all 10 specimens. If 2 or more of these specimens ignite and burn the stop cord, average the results from those specimens. If only 1 of the 10 specimens ignites and burns the stop cord, samples are acceptable.

A6.6.2 *Raised Surface Fabrics:*

A6.6.2.1 Specimens are acceptable if:

(1) All specimens either did not ignite, ignited but self-extinguished, or any combination thereof.

(2) Average burn time is 4 s or greater.

(3) Average burn time is less than 4 s and all specimens burn with a surface flash where the intensity of the surface flame is insufficient to ignite, char, or melt the base fabric.

(4) Only 1 of 5 specimens ignites and burns in less than 4 s and the base fabric does not ignite or fuse, the sample is acceptable.

(5) Only 1 of 5 specimens ignites or burns in more than 4 s, regardless of whether the base fabric ignites or fuses, the sample is acceptable.

A6.6.2.2 To compute the average time of flame spread for each set of 5 specimens, at least 2 of the specimens must ignite and burn the stop cord.

A6.6.2.3 If only 1 of 5 specimens ignites and burns in less than 4 s where the base fabric ignites or fuses, test another set of 5 specimens. Compute the average time of flame spread for all 10 specimens. If 2 or more of the 10 specimens ignite and burn the stop cord, average the results from those specimens. If only 1 of the 10 specimens ignites and burns the stop cord, samples are acceptable.

A6.6 Requirements

A6.6.1 *Plain Surface Fabrics:*

A6.6.1.1 Specimens are acceptable if:

(1) All specimens either did not ignite, ignited but self-extinguished, or any combination thereof.

(2) Average burn time is 3.5 s or greater.

A6.6.1.2 If only 1 of 5 specimens ignites and burns the stop cord with a time of 3.5 s or more, samples are acceptable.

A7. COMPOSITING PROCEDURE FOR TOTAL HEAVY METAL ANALYSIS

A7.1 Purpose

A7.1.1 Composite testing for a total digestion analysis may be conducted to potentially reduce the number of tests conducted. Combining different but like materials into a composite analysis must be done with adequate care and understanding of the limitations and potential propagations of error in measurement or the test may fail to detect excessive metals in one of the individual materials.

A7.2 Definitions

A7.2.1 *Composite Testing – Different Materials*—Combining different but similar materials to reduce the number of digestions and instrumental metal analyses performed.

A7.2.2 *Similar or Like Materials*—Materials that have similar characteristics may be combined into one composite sample. Glass may be composited together; and plastics composited together; however glass and plastic may not be composited together as they require different digestant mixtures to achieve complete digestion. Coatings on metal substrates should not be composited with coatings on non-metal substrates.

A7.3 Exclusions

A7.3.1 Metal substrates with different compositions should not be composited together as one may interfere in the digestion process and cause re-precipitation or incomplete digestion, therefore affecting the actual result.

A7.4 Sample Preparation

A7.4.1 Each individual component must be weighed individually with sufficient precision and sufficient safety factors to assure that no false negatives are reported.

A7.4.2 Sufficient materials must be used for each of the components giving proper consideration for the weighing capabilities of the balance used and the detection limits and necessary dilution for the subsequent instrumental analysis.

A7.4.3 The combined materials are digested according to the appropriate procedure, depending on the material, before analysis by atomic spectroscopy or other appropriate validated method.

A7.4.4 Appropriate weights of each of the individual materials composited depend on final dilution volumes, weighing accuracy, and detection limits.

A7.4.5 Equal weights (to the extent achievable by good laboratory practice) of each of the similar or like materials must be used in the composite sample.

A7.5 Calculation

A7.5.1 As an example, results for the Arsenic (As) content are calculated and reported as follows:

$$\text{Total As concentration: \%As (wt./wt.)} = 0.10cd/w \quad (\text{A7.1})$$

where:

c = concentration of arsenic detected ($\mu\text{g/ml}$)

d = dilution volume (mL)

w = weight of aliquot digested (mg)

A7.5.1.1 One example of composite testing of different plastics would be as follows, and considers the case of weighing to the nearest 0.01 mg, digesting in acid, diluting to a final volume of 10 or 20 mL, and testing on an ICP-OES with an MDL of 0.04 $\mu\text{g/mL}$. A sample comprising red, green, and orange plastics is tested as a composite using 15.0 mg of red plastic, 16.0 mg of green plastic, and 17.0 mg of orange plastic. The resulting 48.0 mg of composite plastic from this example is digested in acid and diluted to 10 ml, and then the diluted digest is found to contain 0.0008 % arsenic. The combined 3 aliquots of plastic would have contributed to a total of 0.40 μg of arsenic for the composite sample. Although the average concentration in this case would be 8 ppm, the individual contributions are not known, and one must calculate the arsenic concentration of each plastic as if all of the arsenic originated from it. Thus, the red plastic could contain up to 0.4 μg / 0.0015 g = 27 ppm ($\mu\text{g/g}$), with similarly calculated results of 25 ppm and 24 ppm for the green and orange plastics. See [Table A7.1](#).

A7.5.2 As another similar example, results for the arsenic (As) content are calculated and reported in [Table A7.2](#). All of individual plastics (11 ppm, 11 ppm, 12 ppm) in the above composite do not exceed 0.0020 % (20 ppm) for arsenic (80 % of 0.0025 % arsenic limit). The composite passes and so do the individual plastics. Therefore the plastics do not need to be tested individually.

A7.5.3 Composite analysis by ICP-MS or another validated method of equivalent sensitivity or the use of a larger sample weight may be necessary when an element has a low regulatory limit and high detection limit (reporting limit), such as with arsenic.

A7.6 Rationale

A7.6.1 Composite heavy element testing of several samples of slightly differing but essentially similar materials (for example, several colors of polyethylene plastic) is desirable to reduce testing cost if this can be accomplished without compromising in any way the achievement of the same attribute (that is, pass/fail) result which would have been reached had the samples been tested individually. [Annex A7](#) outlines detailed procedures for accomplishing this end by specifying the conditions under which compositing is allowable, when a composite result may be relied upon without further testing, and when testing of individual samples must subsequently be performed. Composite testing has been limited to total digestion (vis-a-vis soluble) analyses primarily in order to align with the European Union harmonized standard [EN 71-3](#), which specifically forbids compositing for its required (soluble) analyses.

TABLE A7.1 Total Arsenic (As) Analysis – Composite Testing

Item Analytical	(c) Results As ($\mu\text{g/ml}$)	(d) Dilution Volume (ml)	Total As (μg)	(w) Sample wt (mg)	Potential As (%) per Component	As (%) Composite
Red Plastic	0.04 ^A	10	0.4 ^A	15.0	0.0027	
Green Plastic	0.04 ^A	10	0.4 ^A	16.0	0.0025	
Orange Plastic	0.04 ^A	10	0.4 ^A	17.0	0.0024	
Total Composite	0.04 ^A	10	0.4 ^A	48.0		0.0008 ^B

^A In a composite of different plastics, the analytical result for the total composite would be applied to each component part as if all the arsenic was in that component plastic.

^B In this example, the arsenic concentration of the combined plastics is 0.0008 %, which is below the 0.002 % arsenic acceptable limit (80 % of the 0.0025 % arsenic limit), however any individual component having a result based on it's sample weight that is greater than 80 % of the heavy metal limit should be retested individually. For example, all of individual plastics in the above composite exceed 0.0020 % for arsenic (80 % of 0.0025 % arsenic limit) so all of the plastics should be tested individually. This calculation and data interpretation would be applied to the remaining heavy metals.

TABLE A7.2 Total Arsenic (As) Analysis – Composite Testing

Item Analytical	(c) Results As (µg/ml)	(d) Dilution Volume (ml)	Total As (µg)	(w) Sample wt (mg)	Potential As (%) per Component	As (%) Composite
Red Plastic	0.04	20	0.8	72.0	0.0011	
Green Plastic	0.04	20	0.8	70.0	0.0011	
Orange Plastic	0.04	20	0.8	66.0	0.0012	
Total Composite	0.04	20	0.8	208.0		0.0004

A8. RATIONALE FOR 2007 REVISIONS

A8.1 Definitions¹⁷

A8.1.1 *Section 3*—New definitions for terms used in this version of Consumer Safety Specification F963:

- hazardous magnet
- hazardous magnetic component
- impulsive sound
- maximum A-weighted sound pressure level
- rattle
- reference
- strap
- tangle or form a loop
- yo-yo elastic tether toy

A8.2 Sound Producing Toys

A8.2.1 *Sections 4.5 and 8.19*—These sections have been totally replace by a new set of requirements and a new test procedure.

A8.2.1.1 These requirements have been developed after extensive review of known research on noise-related injury to hearing and existing published recommendations for noise limits. They are intended to reduce the risk of damage to hearing due to high continuous and impulse noise levels. They apply only to toys that are designed to emit sound, i.e., toys that have sound producing features such as electric or electronic devices, percussion caps, rattling components, etc.

A8.2.1.2 The requirements in *4.5.1.1* and *4.5.1.2* are intended to address those hazards presented by continuous sounds (e.g., speech, music). These hazards are chronic and typically manifest themselves after years of exposure. The Occupational Safety and Health Administration (OSHA) has set acceptable limits at 85 dB(A) for 8 h of exposure. An independent audiologist consulted by the ASTM work group recommended a similar exposure level. His recommendations for an 8 h exposure level, Leq, 8h, were 85 dB(A) for continuous sound, and 82 dB(A) for the continuous sound emitted from toys that produce both continuous and impulsive sound.

A8.2.1.3 Exposure to noise from toys is intermittent and integrated with other daily noises. It is unlikely that a toy would present 8 h continuous exposure to sound. These assumptions are consistent with the findings of European research conducted by ISVR Consultancy Services in South-

ampton U.K. and published as “Noise from Toys and its Effect on Hearing.” Based on that study, the probable duration of play with a sound producing toy was determined by the ISVR to be 1.5 h per day.

A8.2.1.4 Using the recommended exposure levels from the audiologist, the ISVR study’s conclusion on the duration of play, and a 3 dB exchange rate, the equivalent recommended values are 92.3 dB(A) and 89.3 dB(A), respectively. Rounding each value to the nearest 5 dB(A) yields 90 dB(A) for both. The ISVR study referenced above also concluded that 25 cm was an average use distance for toys. However, a 50 cm distance is superior for measurement purposes. Therefore, the 25 cm, 90 dB(A) requirement was converted to its 50 cm equivalent. The 50 cm free-field equivalent of 90 dB(A) at 25 cm is 84 dB(A). This was rounded to 85 dB(A) to arrive at the final requirement.

A8.2.1.5 The ISVR study uses a distance for close-to-the-ear toys of 2.5 cm. Using the same reasoning applied above, the 50 cm free-field equivalent of 2.5 cm, 90 dB(A) is 64 dB(A). This was rounded to 65 dB(A) to arrive at the final close-to-the-ear-toy requirement.

A8.2.1.6 The requirements in *4.5.1.3-4.5.1.5* are intended to address those hazards presented by impulsive sounds (e.g., percussion caps), which can be especially hazardous. Permanent damage to hearing may occur after only one exposure to high impulsive sound levels.

A8.2.1.7 A technically accurate impulsive sound requirement would involve a combination of decibel levels and number of repetitions per day of the sound and also determining the potential for misuse (actuating close to the ear). This alternative would result in some subjective determinations regarding repetitions/day and the likelihood for actuating close to the ear. Therefore, a conservative approach was adopted that limits impulsive sounds to 120 dB (C-weighted peak). This requirement protects against misuse and allows up to 10 000 repetitions per day according to OSHA guidelines. The 50 cm free-field equivalent of 25 cm, 120 dB(C) is 114 dB(C). This was rounded to 115 dB(C) to arrive at the final requirement. This requirement only applies to impulsive sounds created by non-explosive means (e.g., two masses colliding).

A8.2.1.8 Impulsive sound level requirements for toys that produce sound from explosion (e.g., caps) have been treated separately. A higher decibel level (125 dB(C)) is allowed for these types of toys because of the human ear’s inability to respond to waveforms with such rapid rise-times such as these.

¹⁷ This rationale pertains only to those changes made in the 2007 edition of Consumer Safety Specification F963. Rationales for previous editions may be obtained from ASTM International Headquarters by requesting Research Report RR:F15-1000.

A8.3 Yo Yo Elastic Tether Toys

A8.3.1 *Sections 4.37 and 8.23*—The task group concluded that the mass on the end of the tether was significant in creating the strangulation potential of a yo yo elastic tether toy. That is why these yo yo products have been associated with near strangulations, and similar products with little mass on the end such as a “sticky” hand have no similar data. The mass was determined by weighing product known to be associated with wrapping around neck. Yo yo elastic tether samples evaluated weighed 0.1 kg (0.2 lb), 0.07 kg (.15 lb), and 0.07 kg (0.15 lb). Estimated weight of sticky hand (hand portion only) is 0.0045 kg (0.01 lb). The appropriate value for the mass at the end of the tether was chosen to be between these two values, 0.02 kg (0.04 lb).

A8.3.1.1 The cord length is based on two times the neck circumference of a 5th-percentile 3-year-old from Childdata, or $2 \times 24.0 \text{ cm} = 48 \text{ cm}$ (18.9 in.). The age of 3 years was chosen based on the age of children involved in the incident data.

A8.3.1.2 The rotational speed of 80 RPM was determined by testing adults and determining the maximum RPM they can achieve rotating a product above their heads. The range of adult speed was 80 – 108 RPM, the average was 90 RPM and the standard deviation was 7 based on a sample size of 14. This was reduced to 80 RPM as an estimate for the speed children 3 to 6 years old can achieve. The incident data indicated that children 3 to 6 years old are most often involved in yo yo elastic tether incidents.

A8.4 Magnets in Toys

A8.4.1 *Section 4.38*—These requirements address the recent incidents of magnet ingestion resulting in serious injury or death by identifying magnets or magnetic components that can be readily swallowed. It requires these hazardous magnets and hazardous magnetic components to be reliably contained in a product, or carry a warning. Hazardous magnets and hazardous magnetic components are identified by describing both a magnetic strength of concern, along with a size and shape that can be swallowed.

A8.4.1.1 The following areas were considered:

(a) Data indicate that powerful magnets have been involved in all known ingestion incidents to date. The data also suggest that magnet ingestion was not a problem in toys until powerful magnets (such as NIB magnets) became cost effective and commonplace several years ago. Ceramic, rubberized, and ferrite magnets have substantially lower attractive forces and therefore must be made larger to provide sufficient magnetism, which makes them less likely to be swallowed.

(b) The magnets/magnetic components involved in the ingestion incidents were small objects (see 4.6 and Fig. 3). Therefore, the requirements have indicated that hazardous magnets or hazardous magnetic components must not be small objects.

(c) The exemptions represent magnets which are used in applications that are not obvious to the consumer. These are very common magnet uses and there are no data associated with these magnets.

(d) Products intended for children under three are already subject to the small parts requirement which would include these magnets or magnetic components.

A8.4.2 *Section 5.17*—The warning specifically explains the hazard as “sticking across intestines.” Studies of warnings show that when the audience can “picture it,” even when there is no picture, then compliance with the warning increases. In the final analysis, the “intestines” statement makes this warning more effective than it would be without it.

A8.4.3 *Section 8.24*—If the play pattern of the toy includes repeated attaching and detaching of the magnet(s), the magnet(s) shall be subjected to repeated attachment and detachment that is expected over the life of the toy. Furthermore, if it is likely that other components included in the toy can attach to the magnet(s), then the magnet(s) and the other components shall be dropped/impacted together during use/abuse testing.

A8.5 Hemispheric Shaped Objects

A8.5.1 *Section 4.36*—Data analysis of the “cupped” shaped objects involved in the fatal and non-fatal incidents, indicated that the wall thickness of the objects involved in the incidents ranged from approximately 0.04 in. (1 mm) to 0.12 in. (3 mm). Based on this data, it was believed that wall thickness was not a concern. It is also important to note that, wall thickness is not a relevant factor for objects with diameters at the upper end of the requirements as these sized objects may fit around/under the chin.

A8.5.1.1 However, since publication of this requirement, questions have been raised in the United States and Europe regarding objects with “thick” walls or rims—what is the appropriate measurement for these objects, inner or outer diameter? The work group has discussed the intent of the requirement and has concluded that the inner diameter measurement is the critical element in determining whether or not a “cupped” shaped object has the potential to fit a child’s face and create a vacuum. Therefore, a change from outer diameter to inner diameter is recommended.

A8.5.2 *Section 4.36.6(e)*—The new option for a single large opening in the base includes the area that is defined by the original two small opening minimum dimensions (0.080 in./2 mm) and the minimum space in between these openings (0.5 in./13 mm). The 0.66 in./17 mm dimension is calculated as $0.080/2 \text{ mm} + 0.080/2 \text{ mm} + 0.5/13 \text{ mm}$. This approach is consistent with the option for ventilation in 4.16.1.1. Similarly, placement of this opening at least 0.5 in. (13 mm) from the rim of the object should ensure that facial features such as the nose or chin, or flesh, will not completely block the opening.

A8.6 Miscellaneous Technical Issues

A8.6.1 *Section 4.12*—The purpose of this section is to minimize the potential of asphyxiation hazards that may be caused by thin packaging film, including sheets and bags. Plastic sheeting/bags may adhere to a child’s mouth and nose making it impossible to breathe. Since the most frequent pattern of death is the covering of the face, the exemption is based on the size of the face and not whether the plastic is a bag or a sheet. CPSC anthropometry data for the face of a 4 to 6-month-old indicates a minimum head height of 125 mm (4.9 in.) and minimum face width of 85 mm (3.3 in.). This is the

basis for the exemption, which is a minor dimension of <3.9 in. (100 mm). Plastic sheets or bags with a minor dimension less than 3.9 in. (100 mm) will not entirely cover the face of a 4 to 6-month-old infant.

A8.6.1.1 Both ISO 8124 and EN 71 allow for perforations of the sheeting if it does not meet the thickness requirements. There is no injury data from the EU to indicate that perforated film presents a hazard. The 1 % area for perforations is considered to be sufficient to sustain an air flow and prevent the adhering of the film to the face.

A8.6.2 *Section 4.14:*

A8.6.2.1 *Section 3.1.75*—Definition of strap added to clarify and expound test method verbiage in 4.14. Children under the age of 18 months have developed certain gross motor skills (e.g., can grasp and pick up objects). However, they lack fine motor skills such as those required to insert the end of cords/straps/elastics through a small opening or to wrap a cord/elastic multiple times around a wheel.

A8.6.2.2 *Section 4.14.1.1*—Details requirements for break-away features on cords, straps, and elastics.

A8.6.2.3 *Section 4.14.2*—Clarifies scope of test method by adding "strap" as an additional type of cord/elastic covered by the requirement.

A8.6.2.4 *Section 8.22.2*—This section provides an additional testing method and supplemental diagrams (with details for additional equipment) that should be used for materials that have a loop perimeter smaller than the tapered end of the head probe.

A8.6.2.5 *Section 8.22.3*—Details testing method for determining the release force required for breakaway features on cords, straps, and elastics.

A8.7 Miscellaneous Editorial Changes

A8.7.1 *Section 4.6*—The word "choking" has been added to the test to be consistent with the language of 16 CFR 1501.

A8.7.2 *Section 4.15.6*—This section references the dynamic strength test in 8.20. This reference had been omitted in the previous version of Consumer Safety Specification F963.

A8.7.3 *Section 4.17*—Reference to the wrong definition has been corrected to 3.1.60.

A8.7.4 *Section 4.25*—Abuse testing in 8.6-8.10 of the standard is not applied to toys intended for children over 96 months (this is laid out in Table 5). Therefore, it is redundant and unnecessary to break down the age group in this way in the requirement section.

A8.7.4.1 *Section 4.25.10.6(2)*—Corrected reference to test procedure to 8.18.7.

A8.7.5 *Section 8.6*—Explicitly states the age requirements as they pertain to abuse testing (for clarification). Also, the word "test" has been corrected to "toy" in the third sentence.

A8.7.6 *Section 8.18.6.1*—The text has been changed to correct errors in the procedure contained in the previous version of this section.

A9. RATIONALE FOR 2008 REVISIONS

A9.1 Jaw Entrapment

A9.1.1 *Section 4.39*—There have been product recalls in past years to address incidents of jaw entrapment. There have been additional incidents of jaw entrapment in toy products that did not rise to the level of a recall. All but one incident involved entrapment in a handle or steering wheel. When a child's jaw becomes entrapped in a product, there is potential for damage to teeth and gums, long term orthodontic consequences and impairment of normal speech development. Most cases of jaw entrapment involve children less than 18 months of age. (See Fig. A9.1 and Table A9.1, and Table A9.2.) There is no incident data indicating handles that are connected to the toy with a hinge and handles made from a pliable material (for example, straps and ropes) pose a risk of jaw entrapment.

A9.1.2 *Anthropometric Data*—The April 1966 study titled "Selected Facial Measurements of Children for Oxygen-Mask Design"¹⁸ provides very useful anthropometric data.

A9.1.2.1 To provide protection for children up to the age of 18 months:

Width—Using the maximum estimated stomion-menton dimension and rounding up, indicates the gauge should be 3.8 cm (1.5 inches) in width.

Length—The 95th percentile mouth breadth for 2 to 3.5 year olds (the youngest age available) is 3.8 cm (1.5 inches) from Chidata (see Table A9.3 and Table A9.4). One inch was added resulting in the 2.5 inch length. A safety factor of 2.54 cm (1 inch) was used for mouth breadth since the anthropometric data is based on a mouth at rest, and a mouth can be expected to stretch significantly from this position. Alternately, the lip length dimensions above can be used to arrive at the same estimate, rounding up, of 6.35 cm (2.5 inches).

A9.1.2.2 To provide protection against the youngest user becoming entrapped:

Width—A gauge width of 1.9 cm (0.75 inches) was chosen based on the minimum stomion-menton distance for a 1 month old.

Length—The small jaw breadth of 1.9 cm (0.75 inches) is based on the 5th percentile 2 year old mouth breadth which is 2.54 cm (1.0 inch), so to be conservative 75 % of that was used.

A9.1.2.3 The task group considered adding a requirement as suggested at the meeting that the scope only cover handles and steering wheels that are able to be placed in the mouth, or would be teethable. The task group considered this suggestion and determined that this modification would not be made since incident data demonstrated that some products created jaw entrapment without the need for the child to place the product in his/her mouth (for example, the child's jaw was entrapped

¹⁸ Young, J. W., "Selected facial measurements of children for oxygen-mask design," AM 66-9, AM Rep., 1966, Apr: 1-11.

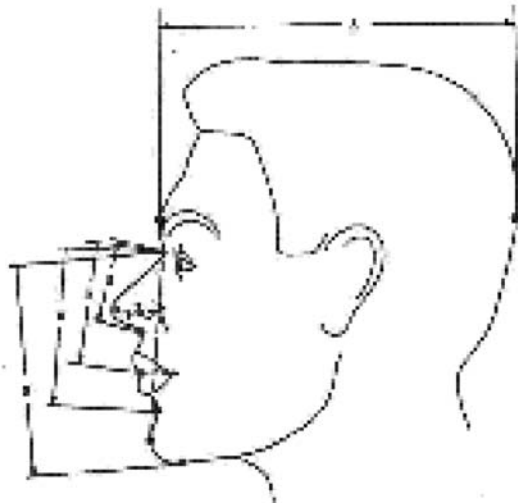

Figure 1. Locations of head and face measurements established by anatomical landmarks (side view).

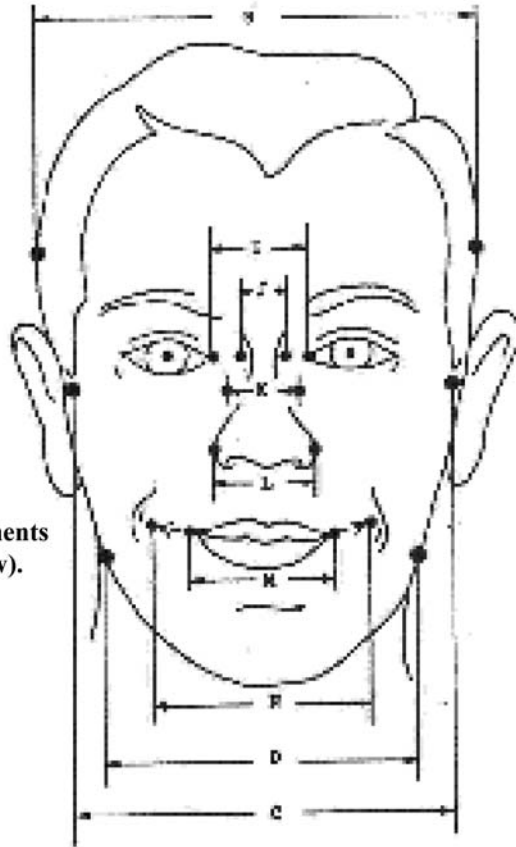

Figure 2. Locations of head and face measurements established by anatomical landmarks (front view).

NOTE—

F: Nasion-Stomion Distance: The distance between the nasal root depression and the point of upper and lower lip intersection.

H: Nasion-Menton: This measurement, taken from the nasal root depression to the lower point on the chin, defines total face height.

M: Lip length, normal: A bilateral measurement (bichelion diameter) of distance between the external corners of the mouth. This measurement is taken with all facial muscles relaxed.

N: Lip length, extended: A bilateral measurement (bichelion diameter) of maximum distance between the corners of the mouth in a condition of voluntary extension using muscles of facial expression.

FIG. A9.1 Facial Measurements

TABLE A9.1 Facial Measurements (in Inches)

Age	# children ^A	Mean Nasion-menton distance ^B	Range Nasion-menton distance	Mean Nasion-stomion distance ^C	Range Nasion-stomion distance	Estimated mean stomion-menton distance	Estimated minimum stomion-menton distance	Estimated maximum stomion-menton distance
1 mo	20	2.36	2.28-2.72	1.58	1.46-1.69	0.78	0.82	1.03
6 mo	20	2.77	2.56-2.95	1.61	1.54-1.73	1.16	1.02	1.22
1 yr	20	2.85	2.68-3.03	1.76	1.69-2.13	1.09	0.99	0.90
2 yr	20	3.14	3.03-3.27	1.98	1.81-2.17	1.16	1.22	1.10
3 yr	20	3.37	3.15-3.66	2.05	1.89-2.20	1.32	1.26	1.46
4 yr	20	3.41	3.19-3.58	2.08	1.57-2.20	1.33	1.62	1.38
5 yr	31	3.49	3.23-3.78	2.16	2.05-2.40	1.33	1.18	1.38
6 yr	91	3.6	3.11-3.98	2.23	2.01-2.56	1.37	1.10	1.42

^A Per the author, sex distribution was reasonably constant across age groups; no sex distinction was made in groups 1 month through 4 years.

^B From nasal root depression to the lower point on the chin (a measure of face height).

^C From nasal root depression to the intersection of the lips.

TABLE A9.2 Lip Length, in Inches

Age	# children ^A	Lip Length, Normal		Lip Length, Extended, extrapolated
		Mean	Range	base on percentage increase in lip length for older children, or 50 % increase over largest normal lip length Maximum
1 mo	20	1.08	0.98-1.26	1.89
6 mo	20	1.09	0.95-1.34	2.01
1 yr	20	1.28	1.14-1.5	2.25
2 yr	20	1.18	0.98-1.5	2.25
3 yr	20	1.38	1.22-1.57	2.35
4 yr	20	1.49	1.26-1.69	2.54

^APer the author, sex distribution was reasonably constant across age groups; no sex distinction was made in groups 1 month through 4 years.

TABLE A9.3 Mouth Breadth^A

Age	Sex	N	Mean (cm)	Sd	5th%ile cm (inch)	95th%ile cm (inch)
2-3.5	Mf	75	3.30	.40	2.70 (1.0)	3.80 (1.5)
3.5-4.5		71	3.40	.40	2.80 (1.1)	3.90 (1.5)

^AFrom Appendix B, Childdata, The Handbook of Child Measurements and Capabilities Data for Design Safety Department of Trade and Industry.

TABLE A9.4 Mouth Opening^A

Age	Sex	N	Mean (mm)	Sd	Min	max
3	M	49	36.0	5.39	22	47
4	M	67	37.3	5.47	22	52
5	M	56	39.9	4.02	27	47

^AFrom Appendix B, Childdata, The Handbook of Child Measurements and Capabilities Data for Design Safety Department of Trade and Industry.

without the need for the child to introduce the handle end of the push toy into the mouth).

A9.1.2.4 The task group considered adding simulated teeth to the gauge. The task group concluded that the addition of teeth was not advisable because the incidents being addressed involved entrapment of the child's jaw. The teeth of the child may have influenced the resulting entrapment, however, the proposed requirement accounts for the presence of the teeth. Also, for a very young child the dimensions of the teeth are variable, since the teeth are just erupting.

A9.1.2.5 The task group added a depth of greater than 1.3 cm (½ inch) to both gauges to clarify that this is a three dimensional test. The depth of 1.3 cm (½ inch) was chosen based on dimensions of products known to be associated with jaw entrapment and the need for only a small portion of the child's jaw to be introduced into the space of the incident products.

A9.2 Folding Mechanisms and Hinges

A9.2.1 *Section 4.13*—The scope of this section has been modified such that the requirement is not limited to toys intended to support the weight of a child. Hinges can present potential pinch hazards regardless of whether the toy is intended to support the weight of a child. Examples and exclusions were reinstated from the previous version of this standard.

A9.3 Locking Mechanisms

A9.3.1 *Sections 8.25.1 and 8.25.2*—The requirements for single- or double-action locking mechanisms are based on Consumer Safety Specification **F406**. This requirement is

intended to ensure that children will not be able to unlock a locking device on their own—a caregiver will be required to unlock the locking device. The requirement for a 45-lbf test on the locking mechanism is based on Consumer Safety Specification **F404**. An exemption for the 45-lbf test was added for products where the direction of the sitting load works against the direction of collapse of the folding mechanism. The requirement has also been modified to require that locking mechanisms or other means engage automatically to protect children who set up the product on their own. Reference to safety stops has been deleted because safety stop was not defined.

A9.4 Yo Yo Elastic Tether Toys

A9.4.1 *Section 4.37.2*—Sports balls are exempt from the Yo Yo Ball requirements, since these requirements were not intended to address this type of product. The work group agreed it will clarify the standard if we specifically exempt them.

A9.5 Impaction Hazards

A9.5.1 *Section 4.32.2*:

A9.5.1.1 This section has been developed to address products intended for children under 48 months of age that meet specific dimension criteria such that they produce a fall-on impaction hazard. This revision is based on incident data provided by the CPSC involving objects that are long enough to be pushed into the mouth, probably past the uvula in a fall-on incident, and large enough to prevent or inhibit removal, even by an adult caregiver. Products less than 2.25 in. (the length of the small parts cylinder) in length are excluded as are products less than 15 mm in diameter. These exemptions are based on the dimensions of products in the incident data. Flexible items are exempt because the flexible end assures they will not create a fall-on impaction hazard.

A9.5.1.2 The impaction hazard addressed by **4.32.2** is different from the hazard associated with preschool play figures addressed in **4.32.3**. The preschool play figures were associated with seven deaths by choking and one incident resulting in serious injury. The incidents involved children under the age of 2 with one exception which involved a developmentally delayed child. In addition there were other choking incidents with the preschool play figures that did not result in significant injury.

A9.5.1.3 The distance to the undercut is based on the dimensions of the small ball test fixture.

A9.5.1.4 The age grade of the product associated with the 2 most recent fatalities was 3+, so this requirement applies to products intended for children under 48 months of age to address the known incident data (ages of victims: 7 mo., 9 mo., 13 mo., 19 mo., 22 mo., 2 yr., 2 yr., 4 yr with severe developmental delay).

A9.5.1.5 There is no force associated with this test because the test is not intended to simulate an actual impaction incident. Rather, it is designed to identify the size and shape of products associated with these incidents.

A9.5.1.6 The supplemental gauge is used to identify the size and shape of objects associated with incident data and is not related to the size of the child for these incidents. Similarly, the

1.1 lb exemption is related to the weight of objects associated with this type of hazard, not the strength capabilities of children.

A9.6 Sound Producing Toys

A9.6.1 *Section 4.5.1.2*—This section contains acoustic requirements that are being interpreted by some laboratories in such a way to fail safe push/pull toys. The requirement needs to be changed for the following reasons:

(1) The standard states in 4.5 that the requirements apply to “toys that are designed to produce sound.” Further to this, the intent of the section is to apply the sound pressure level requirements to those features of the toy designed to produce sound. During the pass-by test for push/pull toys, the contact between the wheels of the product and the test surface will produce a continuous sound that will significantly contribute to the overall sound pressure measurement. The tester will be unable to distinguish between the contributions to the overall sound level made by the wheels versus those made by the mechanism designed to produce sound. Therefore, a true measurement of the intended continuous sound producing mechanism cannot be achieved by the methodology given in the standard.

(2) Among other factors, the levels in the standard are based on a use distance of 25 cm (do not confuse this with the measurement distances specified in the standard). The distance from the noise producing mechanism to the ear of the child on the push/pull toys discussed here would be much greater than 25 cm. Because the relationship between sound pressure level and distance follows the inverse square law, an increase in the distance from the sound mechanism to the ear of the child

would reduce the sound pressure level at the ear of the child dramatically. The risk of hearing loss would be reduced to such an extent as to make it insignificant.

(3) It is implausible that a child could sustain the maximum speed at which the push/pull toy is tested (2 m/s). The speed represents a “worst-case” condition that would only be achievable momentarily at best. This supports regulating against immediate, acute hazards such as impulsive sounds versus chronic hazards that are presented by exposure to long-term, excessively loud continuous sounds.

A9.6.2 In addition, the proposed change would further harmonization between this standard and the European toy standard **EN 71-1**.

A9.7 Magnets

A9.7.1 *Sections 4.38, 5.17, and 8.24*—These sections were revised to account for the incidents (ingestions) due to magnetic components that were small parts and to reflect the age of the children involved with the incidents. It also introduces the special use and abuse requirements to avoid magnets from detaching from magnetic components during play.

A9.8 Toy Chests

A9.8.1 *Deletion of Sections 4.27, 6.2, 7.2, and 8.14*—Toy chests are considered as children’s furniture and have their own set of safety requirements that are already covered in Consumer Safety Specification **F834**.

NOTE A9.1—The section numbers above refer to the previous version of the standard; the subsequent sections have been renumbered in the current version.

A10. RATIONALE FOR 2011 REVISIONS

A10.1 Certain Toys with Nearly Spherical Ends

A10.1.1 *Section 4.32*:

A10.1.1.1 The requirements of 4.32.2 do not apply to tethered components as specified in the exclusions because it is highly unlikely a child will have an impact injury associated with such a tethered component given the weight of the product and the length of the tether. Also, there is no incident data associated with the tethered components being excluded.

A10.1.1.2 Following are examples provided and suggested interpretation as to whether these shapes fall within the scope of 4.32.2 of Consumer Safety Specification F963. These interpretations assume that the dimensions of the part and age grade of the product are such that it falls within the scope of 4.32.2.

Requirements of 4.32.2 apply to this domed peg, even if the very center of the head is flat or has a through hole.



Requirements of 4.32.2 do not apply to this mallet since it is not a nail, screw, peg, or bolt.



The requirements of 4.32.2 do apply to this item because the end is domed.



Requirements of 4.32.2 do not apply to these toy fasteners because the end is not spherical, hemispherical or domed. The end is flat across the top.



The requirements of 4.32.2 do apply. These are toy bolts with domed tops.

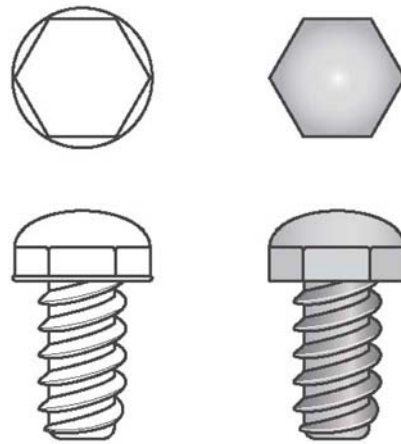

A10.2 Test for Stability of Ride-On Toys or Toy Seats

A10.2.1 *Subsection 8.15.4*—To distinguish between the load placement for fore and aft stability and sideways stability. With the current test methodology, some laboratories and auditors have mistakenly taken the requirements in this subsection to mean both fore and aft stability and also sideways stability. Subsection 8.15.4 states, “The center of gravity of the load for all ride-ons shall be secured both 1.7 in. (43 mm) rearward of the front-most portion of the designated seating area and 1.7 in. (43 mm) forward of the rear-most portion of the designated seating area (note: two separate tests). If there is no designated seating area, the load shall be placed at the least favorable position that it is reasonable to anticipate that the child will choose to sit.”

A10.2.1.1 As you can see, 8.15.4 only addresses fore and aft stability. Additional rationale can be found in the original test methods from the *Voluntary Product Standard PS 72-76*. In Section 4.15.1.1 (d) it states, “The load shall be applied so that its center of gravity lies in a true vertical 6 inches above the center of the seat.” In Section 4.15.2 it states, “The load shall be applied in the least favorable position on the seat for each direction.”

A10.3 Abuse Testing

A10.3.1 *Table 5*—*Table 5* is specifically written to address the drop test, which is a subsection of impact testing. *Table 5* is written to address the drop test. This is a technical correction to the table.

A10.4 Test for Overload of Ride-On Toys and Toy Seats

A10.4.1 *Section 8.26*—There is no test method currently specified for overload therefore this test method is being proposed and it is consistent with the way independent test labs have been performing the test.

A10.5 Stability and Over-Load Requirements

A10.5.1 *Section 4.15*—Wherever “seat” appears in this section, it has been changed to “toy seat” and a definition for toy seats has been developed. The issue is that furniture is exempt from Consumer Safety Specification F963, however, toys that are their counterparts are covered. It can be difficult to

discern between a toy seat and a piece of children’s furniture. Therefore, these changes are proposed to clarify that the scope of this standard only applies to toy counterparts of furniture and juvenile products.

A10.6 Plastic Film

A10.6.1 *Section 4.12*—This section applies to “flexible plastic film bags and flexible plastic sheets used as packaging materials for shelf packages or used with toys.” The title refers to packaging film but the requirement refers to plastic film used with toys. The wording was changed to clarify the scope of the requirement. Also deleted part of the test method section, which is already covered by the requirement section.

A10.7 Teethers and Teething Toys, Rattles, and Squeeze Toys

A10.7.1 *Sections 4.22, 4.23, and 4.24*—The change to exempt soft-filled (stuffed) toys from the rattles, squeeze toys and teethers sections is being made to be consistent with exemptions found in: *16 CFR 1510*, Rattles; EN-71, Clause 5.8, Shape and Size of Certain Toys; and with Consumer Safety Specification F963, Section 4.32, Certain Toys with Nearly Spherical Ends. However, if a stuffed toy contains an internal rigid component (rigid is defined in Consumer Safety Specification F963 as material with a hardness >70 Shore A scale durometer) then the gauges would be applied. If the rigid internal component does not penetrate the full depth of the gauge(s), the toy would PASS. If the rigid internal component does penetrate the full depth of the gauge(s) the toy would FAIL if the major dimension of the rigid component is >1.2 in. (30 mm) or would PASS if the major dimension of the rigid component is <1.2 in. (30 mm). The rigid internal component requirements harmonize with the requirements of EN-71, Clause 5.8.

A10.8 Jaw Entrapment in Handles and Steering Wheels

A10.8.1 *Section 4.39*—There have been product recalls in past years to address incidents of jaw entrapment. There have been additional incidents of jaw entrapment in toy products that did not rise to the level of a recall. All but one incident involved entrapment in a handle or steering wheel. When a

child's jaw becomes entrapped in a product, there is potential for damage to teeth and gums, long term orthodontic consequences and impairment of normal speech development. Most cases of jaw entrapment involve children less than 18 months of age. (See Fig. A9.1, Table A9.1, and Table A9.2.) There is no incident data indicating handles that are connected to the toy with a hinge and handles made from a pliable material (for example, straps and ropes) pose a risk of jaw entrapment.

A10.8.2 *Anthropometric Data*—The April 1966 study titled “Selected Facial Measurements of Children for Oxygen-Mask Design”¹⁸ provides very useful anthropometric data.

A10.8.2.1 To provide protection for children up to the age of 18 months:

Width—Using the maximum estimated stomion-menton dimension and rounding up, indicates the gauge should be 3.8 cm (1.5 in.) in width.

Length—The 95th percentile mouth breadth for 2 to 3.5 year olds (the youngest age available) is 3.8 cm (1.5 in.) from Childata (see Table A9.3 and Table A9.4). One inch was added resulting in the 2.5 in. length. A safety factor of 2.54 cm (1 in.) was used for mouth breath since the anthropometric data is based on a mouth at rest, and a mouth can be expected to stretch significantly from this position. Alternately, the lip length dimensions above can be used to arrive at the same estimate, rounding up, of 6.35 cm (2.5 in.).

A10.8.2.2 To provide protection against the youngest user becoming entrapped:

Width—A gauge width of 1.9 cm (0.75 in.) was chosen based on the minimum stomion menton distance for a 1 month old.

Length—The small jaw breadth of 1.9 cm (0.75 in.) is based on the 5th percentile 2 year old mouth breadth which is 2.54 cm (1.0 in.), so to be conservative 75 % of that was used.

A10.8.2.3 The task group considered adding a requirement as suggested at the meeting that the scope only cover handles and steering wheels that are able to be placed in the mouth, or would be teethable. The task group considered this suggestion and determined that this modification would not be made since incident data demonstrated that some products created jaw entrapment without the need for the child to place the product in his/her mouth (for example, the child's jaw was entrapped without the need for the child to introduce the handle end of the push toy into the mouth).

A10.8.2.4 The task group considered adding simulated teeth to the gauge. The task group concluded that the addition of teeth was not advisable because the incidents being addressed involved entrapment of the child's jaw. The teeth of the child may have influenced the resulting entrapment, however, the proposed requirement accounts for the presence of the teeth. Also, for a very young child the dimensions of the teeth are variable, since the teeth are just erupting.

A10.8.2.5 The requirement was modified to clarify the gauges must pass completely through the opening. The gauge depth was modified from the original requirement of greater than ½ in. to the present requirement of 1 in. When passing the gauge through the opening, a depth must be specified to assure the test results are consistent.

A10.9 Strings and Lines for Flying Devices

A10.9.1 *Subsection 4.14.4—EN 71-1* (Clause 4.13) and *ISO 8124-1* (Clause 4.11.7) both use “resistance” instead of “resistivity.” Resistance = resistivity × length/area, therefore, this change is being made for consistency. Also, the units have been corrected to ohms per centimetre (Ω/cm).

A10.10 Heavy Elements

A10.10.1 *Subsections 4.3.5 and 8.3:*

A10.10.1.1 The soluble approach for determination of heavy elements in toys and toy components has been selected over total element limits as this has been demonstrated to be more closely correlated with the amount of element which is bioavailable, and therefore with risk of toxicity. These requirements (and test methods) and this rationale have been based on requirements from European toy safety requirements found in *EN 71-3* (and *ISO 8124-3*).

A10.10.1.2 The scope is intended to indicate an approach to the decision of what toys, or toy components are excluded from the standard because of characteristics that render them unlikely to present a risk of injury by the ingestion of materials containing the toxic elements.

A10.10.1.3 Toys and toy components that are accessible to the child during play are subject to these requirements unless otherwise indicated. Some materials such as metal, glass, and ceramic are exempted if they are not small parts.

A10.10.1.4 Unless included in a toy, modeling clays, which are covered in the *EN 71-3* requirements for heavy metals are not covered in these heavy metals requirements because they are already exempt from Consumer Safety Specification F963 as indicated in 1.4 and subject to the federal requirements of LHAMA.

A10.10.1.5 The list of excluded materials is based on the regulatory exclusions provided by the U.S. Consumer Product Safety Commission (CPSC), specified at *16 CFR 1500.91*, in implementation of the requirements for lead and lead paint under Section 101 of the Consumer Product Safety Improvement Act (CPSIA) of 2008. While *EN 71-3* includes test methods for Paper and paperboard and Textiles (natural and synthetic), given the exemption for these products test methods for them have not been included here.

A10.10.1.6 Sections *8.3.2-8.3.6* provide a test procedure and manner of interpretation of results for solubility testing.

A10.10.1.7 As in EN 71, solubility testing is called for in the proposed ASTM standard. However, note that as described in *8.3.6*, an alternative approach may be used if validated per specified requirements.

A10.10.1.8 Component parts and materials may be separately tested and certified.

A10.11 Yo Yo Elastic Tether Toys

A10.11.1 *Sections 4.37 and 8.23*—The task group concluded that the mass on the end of the tether was significant in creating the strangulation potential of a yo yo elastic tether toy. The risk of strangulation appears much lower for products with very light ends compared to the yo-yo type balls as seen on the market in 2003 with end weights of 65 to 85 g (0.14 to 0.19 lb). The lightweight end results in very slow rotational speed when

swung overhead and there is much less recoil capacity of the tether due to significantly lower loading during rotation. Additionally, the lightweight “sticky hand” variety of yo-yo elastic tether toy had market presence, prior to 2003, with no reports of near-miss strangulation or other similar incident. The mass was determined by weighing product known to be associated with wrapping around the neck incidents. Yo yo elastic tether toy samples evaluated weighed 0.10 kg (0.2 lb), 0.07 kg (0.15 lb), and 0.07 kg (0.15 lb). The weight of four “sticky hand” variety of yo-yo elastic tether toys (hand portion only) was 0.005 kg (0.01 lb) 0.008 kg (0.02 lb), 0.009 kg (0.02 lb) and 0.012 kg (0.03 lb). The appropriate value for the mass at the end of the tether was chosen to be between these values, 0.02 kg (0.04 lb).

A10.11.1.1 The cord length is based on two times the neck circumference of a 5th-percentile 3-year-old from Childata, or $2 \times 24.0 \text{ cm} = 48 \text{ cm}$ (18.9 in.). The age of 36 months and over was chosen based on the age of children involved in the incident data.

A10.11.1.2 The rotational speed of 80 RPM was determined by testing adults and determining the maximum RPM they can achieve rotating a product above their heads. The range of adult speed was 80 – 108 RPM, the average was 90 RPM and the

standard deviation was 7 based on a sample size of 14. This was reduced to 80 RPM as an estimate for the speed children 36 months and over but under 72 months of age can achieve. The incident data indicated that children 36 months and over but under 72 months of age are most often involved in yo yo elastic tether toy incidents.

A10.11.1.3 The use of a cam with a variable speed drill assists in spinning the toy in the air. Specification of a cam length is required in order to achieve consistent results across laboratories, given that the length affects the load on the tether during rotation. The objective was to employ as short a length as possible, but one that would facilitate clamping and rotation of the toy. A 3 cm (1.18 in.) cam length was identified as one that adequately met both objectives.

A10.12 Miscellaneous

A10.12.1 *Sections 1.4 and 3*—For clarification, juvenile products, constant air inflatables, powered and no-powered scooters have been added to the list of products which are not covered by the toy standard. Definitions for juvenile products and constant air inflatables have been added to the terminology section.

ASTM International takes no position respecting the validity of any patent rights asserted in connection with any item mentioned in this standard. Users of this standard are expressly advised that determination of the validity of any such patent rights, and the risk of infringement of such rights, are entirely their own responsibility.

This standard is subject to revision at any time by the responsible technical committee and must be reviewed every five years and if not revised, either reapproved or withdrawn. Your comments are invited either for revision of this standard or for additional standards and should be addressed to ASTM International Headquarters. Your comments will receive careful consideration at a meeting of the responsible technical committee, which you may attend. If you feel that your comments have not received a fair hearing you should make your views known to the ASTM Committee on Standards, at the address shown below.

This standard is copyrighted by ASTM International, 100 Barr Harbor Drive, PO Box C700, West Conshohocken, PA 19428-2959, United States. Individual reprints (single or multiple copies) of this standard may be obtained by contacting ASTM at the above address or at 610-832-9585 (phone), 610-832-9555 (fax), or service@astm.org (e-mail); or through the ASTM website (www.astm.org). Permission rights to photocopy the standard may also be secured from the ASTM website (www.astm.org/COPYRIGHT).